



1300 Series Differential Pressure Gauge Operating and Installation Instructions

Gauge Inspection:

Please read the product specification label attached to the gauge body to insure that this gauge is the same gauge specified for the particular application as it applies to dial size, materials of construction, working pressure, differential pressure, etc. Inspect for any damage and, if discovered, report it immediately.

Product Design Features:

The NOSHOK 1300 Series is designed for working pressures to 600 psig and differential pressure to 600 psid. This series is supplied, standard, with a 6" dial or, optionally, with a 4.5" dial. The gauge has a 316L sensor cell, encapsulating opposed, high (+) and low (-) side SS membranes in a Halocarbon liquid fill. The high (+) side pressure works against the membranes and the fill, causing them to move. This movement is transferred to a torque-tube assembly, linked to a horizontally moving, bidirectional overpressure valve (This valve protects the sensor membranes against damage from high (+) or low (-) side overpressure of the membranes in the sensor cell.) A torsion rod, located within the torque-tube assembly, passes through a sealed compression tube fitting (which isolates the sensor cell from the dial case assembly) into the dial case and is connected to the pinion/sector gear and pointer assembly. The twisting motion of the torsion rod, driven by the membrane movement, is magnified to a 270 Degree, linear arc and pointer travel.

Gauge Mounting:

Design and Operating Principle

- Process pressures p_1 and p_2 are applied to the chambers - (2) and + (3).
- Gauge head (4) is filled with liquid.
- Differential pressure across + and - pressure sides deflects the diaphragm (1) and displaces the liquid.
- The displacement of the connection rod (5) is converted through the use of a transmitting lever (6) into rotation, which is transferred over an axial shaft (7) to the movement (9).
- The torque pipe (8) seals, assuring a frictionless path.
- Overpressure protection in both directions up to the max. static pressure rating is provided by contoured metal bolsters.

The NOSHOK 1300 Series gauge is supplied, standard, with four (4) threaded studs and locking nuts. The gauge is mounted in the panel from front to back and secured to the back of the panel with the threaded studs and locking nuts. Optional 2" pipe mount kit or wall mount kits are available (for units with top/bottom mount connections only)..

Gauge Connections:

Standard dual (2) x 1/4" FNPT top/bottom connections with high (+) and low (-) connections clearly indicated. Optional connection sizes and/or back connections are available

Troubleshooting:

If the gauge is not indicating differential pressure, check to insure that both the high (+) and low (-) connections have been properly installed. Check to insure that there is differential pressure across the device being monitored by the NOSHOK 1300 Series gauge. If the gauge is being used together with a three-valve manifold (recommended), check to insure that the high (+) and low (-) valves are in the open position and the equalizer valve is in the closed position. If, after following these steps with no positive result, please contact the NOSHOK Customer Service Department or your nearest NOSHOK Distributor.

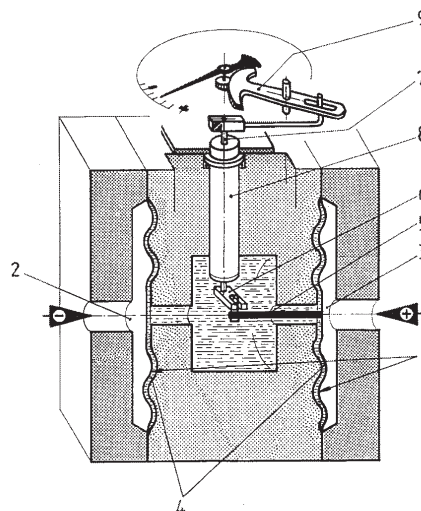

The
Instrumentation
Company



Corporate Headquarters

1010 West Bagley Road
Berea, Ohio 44017
Ph: 440.243.0888
Fax: 440.243.3472
E-mail: noshok@noshok.com
Web: www.noshok.com