

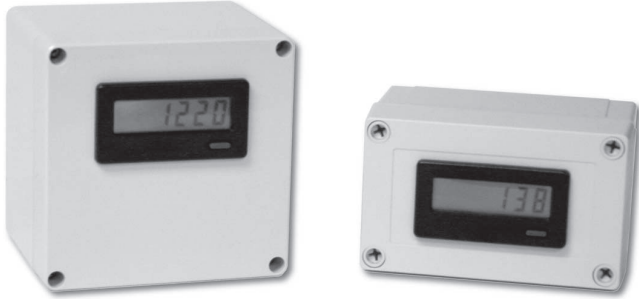

# NEMA 4 ENCLOSURES FOR 1900 & 1950 SERIES

## PLASTIC ENCLOSURES



### ENC2 DIMENSIONS In inches (mm)

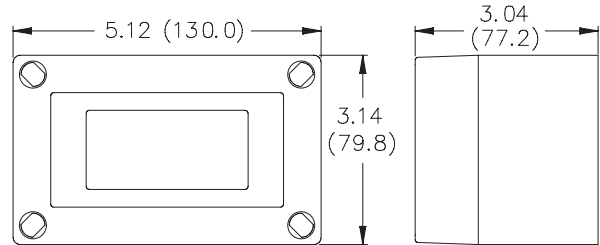

### DESCRIPTION

These enclosures are designed for applications requiring a water resistant instrument enclosure. The enclosures are fabricated of polycarbonate and are designed to withstand NEMA 4X/IP65 wash-down applications. The enclosures must be drilled to accept conduit fittings or other types of wiring connectors. The enclosures can be used free-standing, or securely fastened to a mounting surface.

### ORDERING INFORMATION

DESCRIPTION	PART NUMBER
Plastic Enclosure for single units	ENC2
Plastic Enclosure for units with a PS3 attached	ENC3

### ENC3 DIMENSIONS In inches (mm)

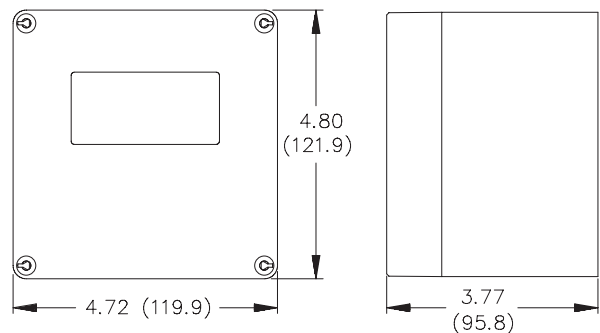

### ENC2 INSTALLATION

It is recommended to wire the unit before mounting it in the enclosure to ensure good electrical connections. The following steps outline the most common sequence for installing a unit without a PS3 attached.

- Determine the location of the conduit fitting and drill the necessary hole. Install the fitting and bring the wiring into the enclosure.
- Slide the panel gasket over the rear of the unit to the back of the bezel
- Assemble nut fastener and mounting screw onto both sides of the mounting clip. The tip of the screw should not project from the hole in mounting clip.
- Install the unit through the opening in the front of the lid until the bezel flange contacts the panel.
- Slide the mounting clip over the rear of the unit until the mounting clip is against the inside of the enclosure. The mounting clip has latching features which engage into mating features on the unit's housing.

Note: It is necessary to hold the unit in place when sliding the mounting clip into position.

- Alternately tighten each screw to ensure uniform gasket pressure. Visually inspect the front panel gasket. The gasket should be compressed to about 75 to 80% of its original thickness (Recommended torque is 28 to 36 in.-oz.). If not, gradually turn mounting screws to further compress the gasket.
- If the gasket is not adequately compressed, and the mounting screws can no longer be turned, loosen the mounting screws and check that the mounting clip is latched as close as possible to the inside of enclosure. Repeat the procedure for tightening the screws.

- Connect the necessary wires to the unit for the application desired
- Assemble the enclosure with the screws provided. Alternately tighten each screw to ensure uniform gasket pressure.

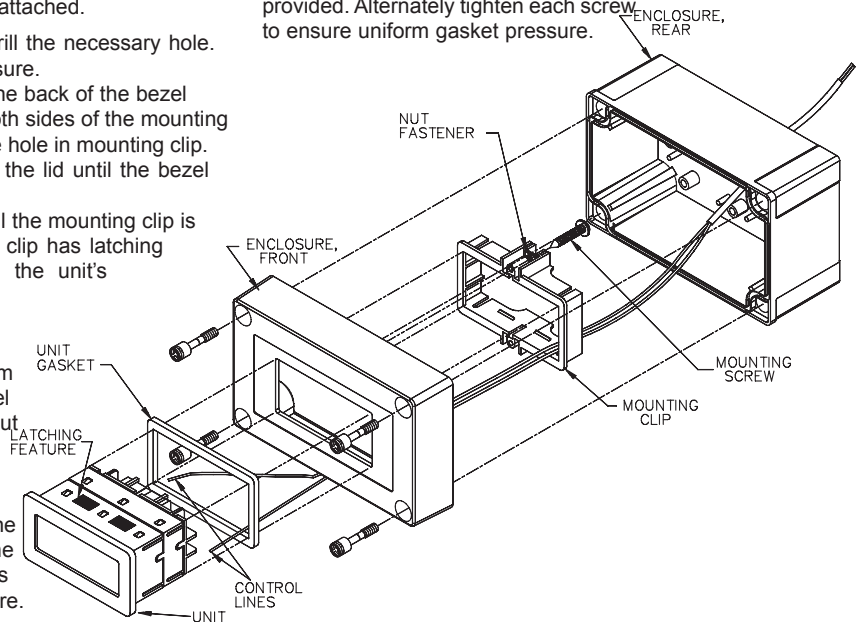

### ENC3 with PS3 Installation

Installing a unit with a PS3 attached requires some planning. It is recommended that the unit with the PS3 attached be temporarily installed in the enclosure to determine the best location for the conduit fitting to avoid interference with the PS3.

1. Determine the location of the conduit fitting and drill the necessary hole. Install the fitting and bring the wiring into the enclosure.
2. Slide the panel gasket over the rear of the unit to the back of the bezel.
3. Remove the common and V+ screw terminals from the rear of the unit (save for later use) and replace them with the stand-offs (supplied with the PS3).
4. Assemble nut fastener and mounting screw onto both sides of the mounting clip. The tip of the screw should not project from the hole in mounting clip.
5. Install the unit through the opening in the front of the lid until the bezel flange contacts the panel mounted gasket.
6. Slide the mounting clip over the rear of the unit until the mounting clip is against the inside of the enclosure. The mounting clip has latching features which engage into mating features on the unit's housing.

Note: It is necessary to hold the unit in place when sliding the mounting clip into position.

7. Alternately tighten each screw to ensure uniform gasket pressure. Visually inspect the front panel gasket. The gasket should be compressed to about 75 to 80% of its original thickness (Recommended torque is 28 to 36 in-oz.). If not, gradually turn mounting screws to further compress the gasket.
8. If the gasket is not adequately compressed, and the mounting screws can no longer be turned, loosen the mounting screws and check that the mounting clip is latched as close as possible to the inside of enclosure. Repeat the procedure for tightening the screws.

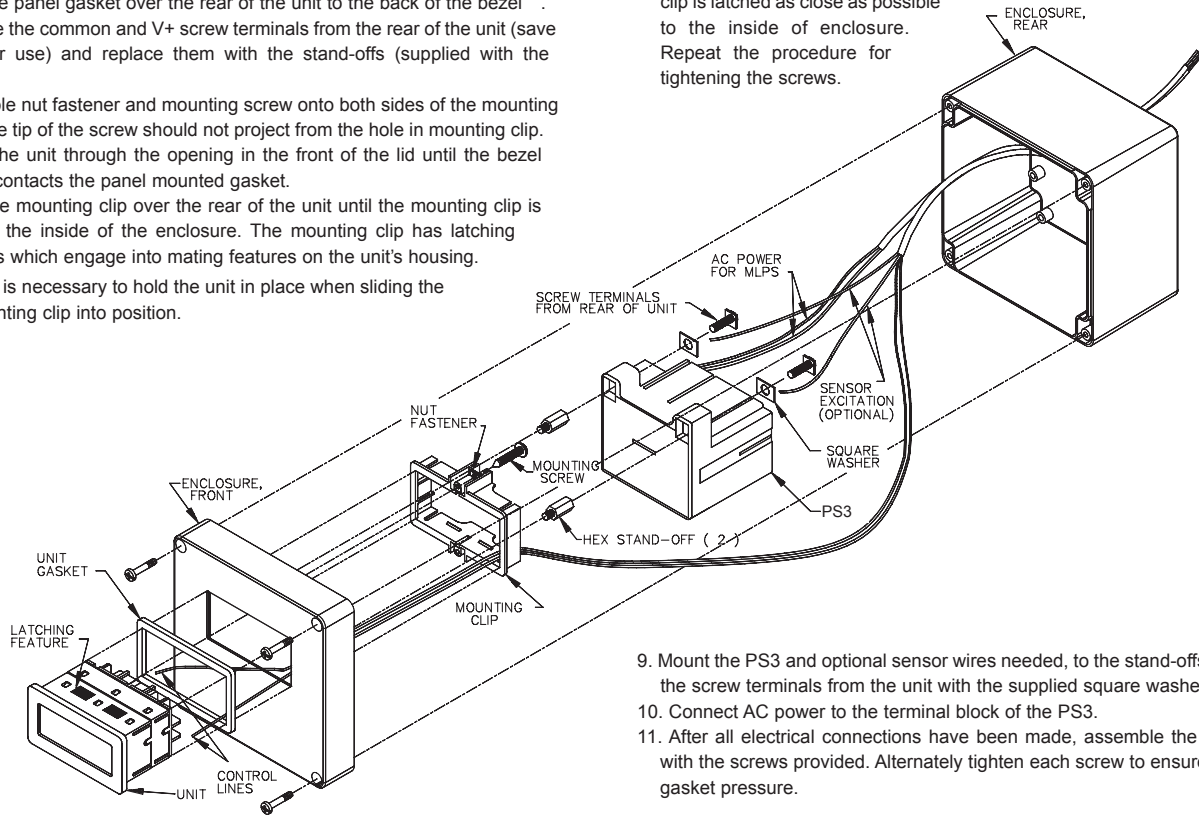

9. Mount the PS3 and optional sensor wires needed, to the stand-offs using the screw terminals from the unit with the supplied square washers.
10. Connect AC power to the terminal block of the PS3.
11. After all electrical connections have been made, assemble the enclosure with the screws provided. Alternately tighten each screw to ensure uniform gasket pressure.

### ENC1 - STEEL ENCLOSURE



#### DESCRIPTION

This enclosure is designed for use with the 1900 & 1950 units. The enclosures are large enough to accommodate a Power Supply (PS3) attached to the unit. These rugged enclosures are fabricated of formed steel with all seams welded to withstand NEMA 4/IP65 wash-down applications. The kits are coated with a durable black polyurethane finish. The holes for conduit fittings or other types of wiring connectors can be drilled through the removable rear access panel, or through the enclosure itself. The enclosures can be free standing or securely fastened to a mounting surface with the brackets and hardware found in the mounting kit (provided with the enclosure). The brackets also allow the enclosure to be raised and/or tilted from the mounting surface in order to achieve the most favorable operating position. Provided are four self-stick foot pads that can be applied to the bottom of the enclosure to protect the mounting surface. The foot pads are particularly useful for free standing installations.

DIMENSIONS In inches (mm)

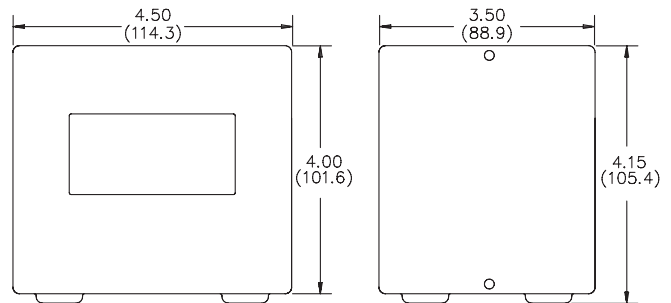

#### ORDERING INFORMATION

DESCRIPTION	PART NUMBER
NEMA 4/IP65 ENCLOSURE	ENC1

## ENC1 INSTALLATION

It is recommended to wire the unit before mounting it in the enclosure to ensure good electrical connections. The following steps outline the most common sequence for installing a unit without an PS3 attached.

1. Determine the location of the conduit fitting and drill the necessary hole.
2. Apply adhesive side of panel gasket to rear enclosure opening.  
**DO NOT APPLY THE ADHESIVE SIDE OF THE GASKET TO THE ACCESS PANEL.**

3. Slide the panel gasket over the rear of the unit to the back of the bezel.
4. Assemble nut fastener and mounting screw onto both sides of the mounting clip. The tip of the screw should not project from the hole in mounting clip.
5. Route the wire to be connected to the unit from the conduit fitting through the mounting clip, and then through the rear of the enclosure and out the front.
6. Connect the necessary wires to the unit for the application desired.
7. Install the unit through the opening in the front of the enclosure until the bezel flange contacts the panel.
8. Slide the mounting clip over the rear of the unit until the mounting clip is against the inside of the enclosure. The mounting clip has latching features which engage into mating features on the unit's housing.

Note: It is necessary to hold the unit in place when sliding the mounting clip into position.

9. Alternately tighten each screw to ensure uniform gasket pressure. Visually inspect the front panel gasket. The gasket should be compressed to about 75 to 80% of its original thickness (Recommended torque is 28 to 36 in-oz.). If not, gradually turn mounting screws to further compress the gasket.

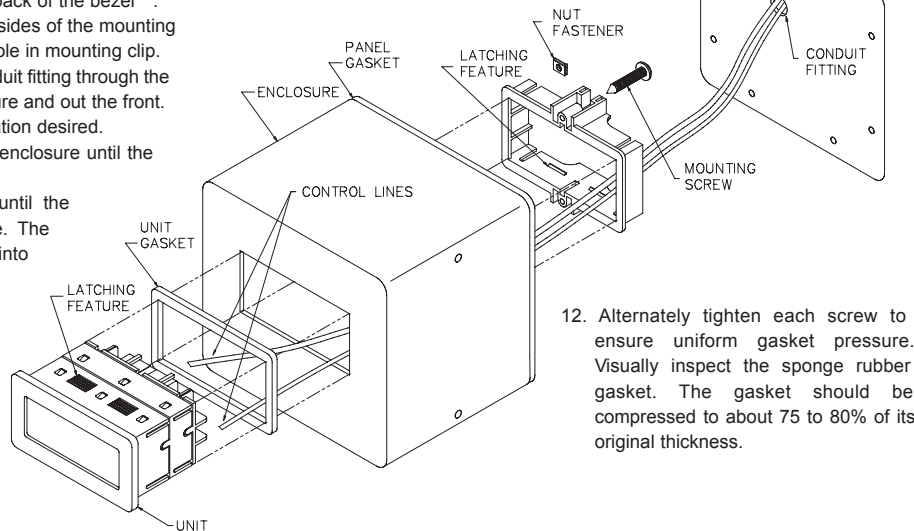

12. Alternately tighten each screw to ensure uniform gasket pressure. Visually inspect the sponge rubber gasket. The gasket should be compressed to about 75 to 80% of its original thickness.

## ENC1 with PS3 Installation

Installing a unit with a PS3 attached requires some planning. It is recommended that the unit with the PS3 attached be temporarily installed in the enclosure to determine the best location for the conduit fitting to avoid interference with the PS3.

1. Mark the location of the conduit fitting and drill the necessary hole.
2. Apply adhesive side of panel gasket to rear enclosure opening.  
**DO NOT APPLY THE ADHESIVE SIDE OF THE GASKET TO THE ACCESS PANEL.**

3. Slide the panel gasket over the rear of the unit to the back of the bezel.
4. Remove the common and V+ screw terminals from the rear of the unit (save for later use) and replace them with the hex drive stand-offs (supplied with the PS3).
5. Assemble nut fastener and mounting screw onto both sides of the mounting clip. The tip of the screw should not project from the hole in mounting clip.
6. Route the wire to be connected to the unit from the conduit fitting through the mounting clip, and then through the rear of the enclosure and out the front.
7. Connect the necessary wires to the unit for the application desired.
8. Install the unit through the opening in the front of the enclosure until the bezel flange contacts the panel mounted gasket.
9. Slide the mounting clip over the rear of the unit until the mounting clip is against the inside of the enclosure. The mounting clip has latching features which engage into mating features on the unit's housing.

Note: It is necessary to hold the unit in place when sliding the mounting clip into position.

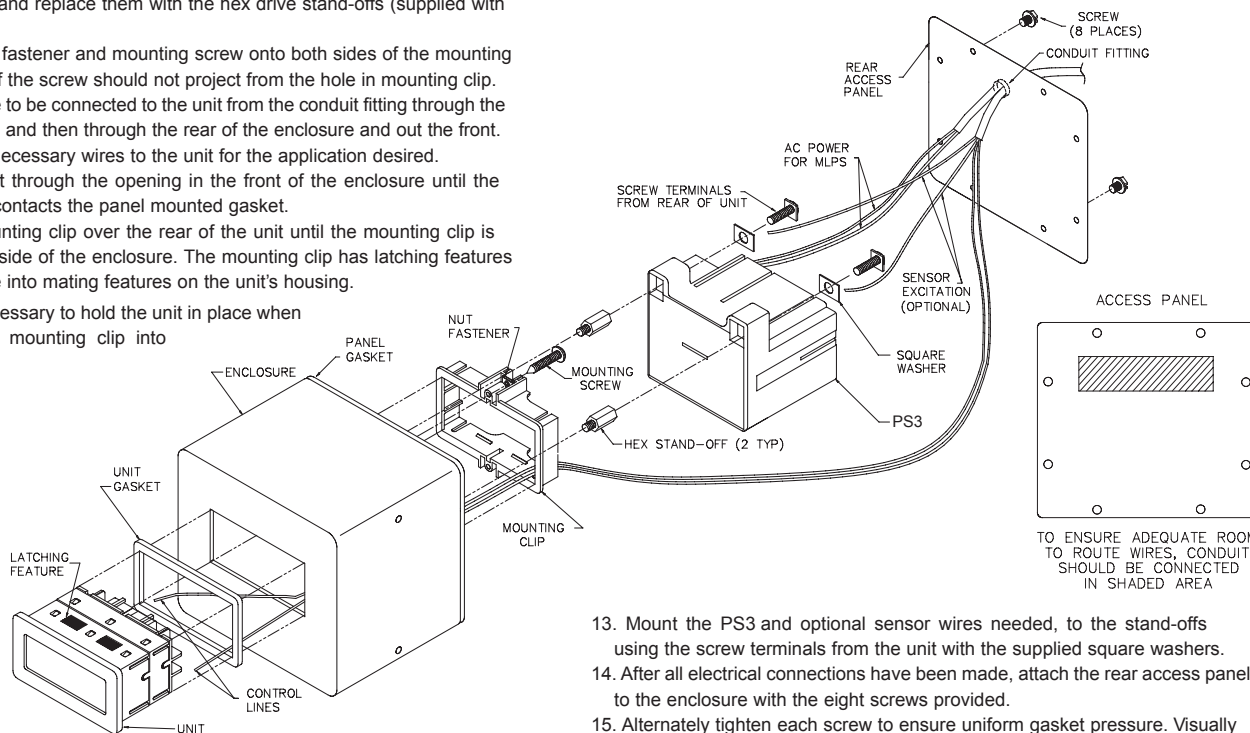

TO ENSURE ADEQUATE ROOM TO ROUTE WIRES, CONDUIT SHOULD BE CONNECTED IN SHADED AREA

10. Alternately tighten each screw to ensure uniform gasket pressure. Visually inspect the front panel gasket. The gasket should be compressed to about 75 to 80% of its original thickness (Recommended torque is 28 to 36 in-oz.). If not, gradually turn mounting screws to further compress the gasket.
11. If the gasket is not adequately compressed, and the mounting screws can no longer be turned, loosen the mounting screws and check that the mounting clip is latched as close as possible to the inside of enclosure. Repeat the procedure for tightening the screws.
12. Connect AC power to the terminal block of the PS3.

13. Mount the PS3 and optional sensor wires needed, to the stand-offs using the screw terminals from the unit with the supplied square washers.
14. After all electrical connections have been made, attach the rear access panel to the enclosure with the eight screws provided.
15. Alternately tighten each screw to ensure uniform gasket pressure. Visually inspect the sponge rubber gasket. The gasket should be compressed to about 75 to 80% of its original thickness.

## MOUNTING THE ENCLOSURE

1. Self-stick foot pads may be applied to the features on the bottom of the enclosure to protect the mounting surface.
2. To securely mount the enclosure, attach the adjustable mounting brackets to the enclosure using the plastic washers and screws. Mounting brackets may be attached to the top or bottom of the enclosure.
3. Secure the adjustable mounting brackets to mounting location with the screws provided.

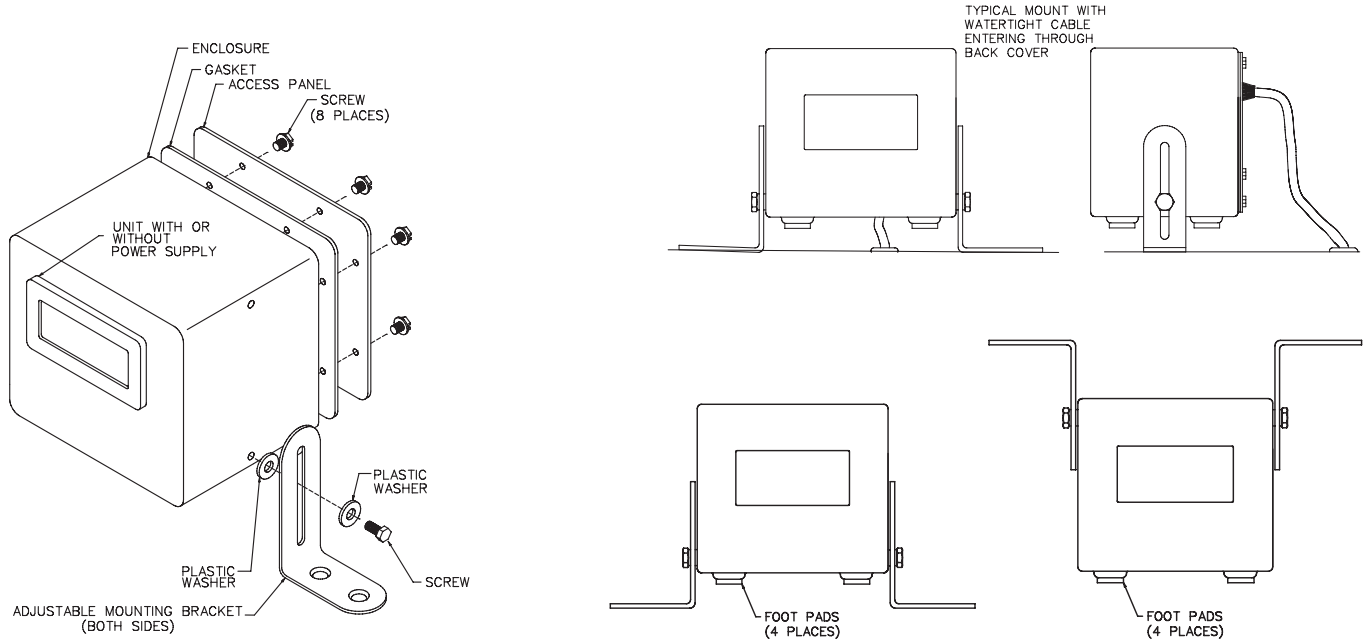

### LIMITED WARRANTY

NOSHOK'S One Year Warranty applies to these products. NOSHOK warrants these products to be free from defects in materials and workmanship, to remain within catalogued accuracy specifications, and to operate within the catalogued performance specifications. Limitations which apply are: These units must be operated within the catalogued environmental and application parameters. Determination of failure will be made by NOSHOK, Inc.'s equipment and personnel or a certified test facility specializing in this type of evaluation.

The  
Instrumentation  
Company

**NOSHOK**  
INCORPORATED

#### Corporate Headquarters

1010 West Bagley Road  
Berea, Ohio 44017  
Ph: 440.243.0888  
Fax: 440.243.3472  
E-mail: noshok@noshok.com  
Web: www.noshok.com

ISO 9001:2008  
REGISTERED

ENC8TM-09