

NOSHOK Transducer and Transmitter Pressure Sensing Technologies

Diffused Silicon Semiconductor Strain Gage Sensor (used in 100, 200, 600, 612, 615, 616, 621, 622, 623, 624, 625, 626, 627, 640, 650, 755 and 756 series - ranges up to 0 psi to 300 psi)

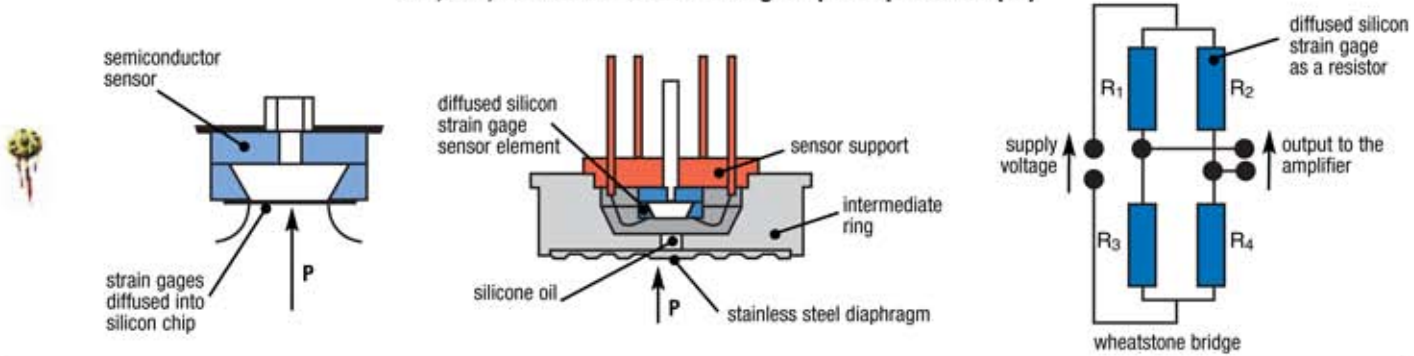

Sputtered Thin Film Strain Gage Sensor (used in 100, 200, 600, 612, 615, 616, 621, 622, 623, 624, 625, 626, 627, 640, 650, 660, 755 and 756 series - ranges 0 psi to 500 psi and higher)

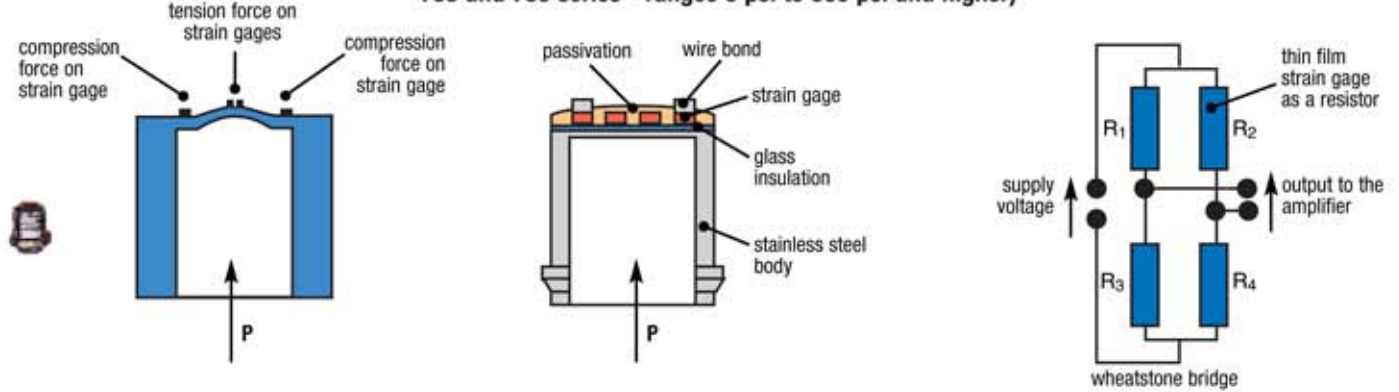

Ceramic Thick Film Strain Gage Sensor (used in 680 and 1000 series)

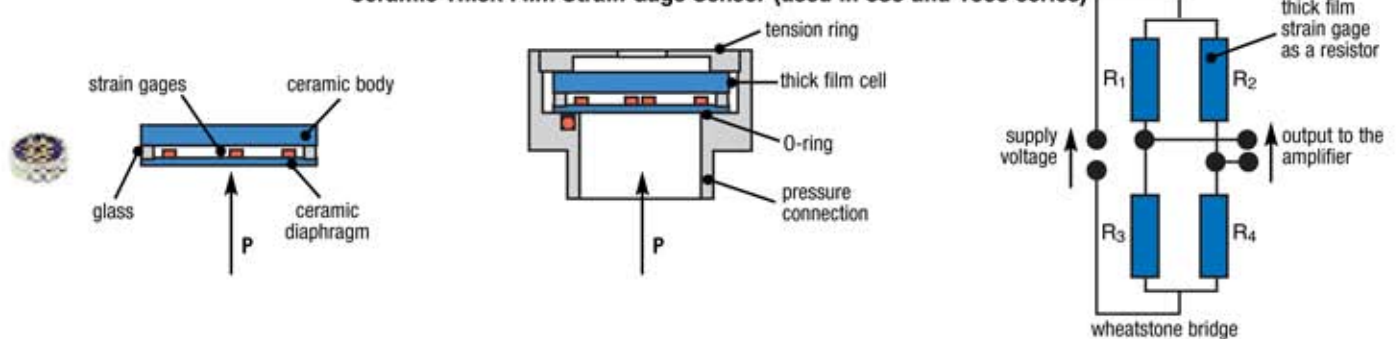

Hall Effect Sensor (used in 630 series)

