



**LTI20 Series**  
Radar Level Transmitter



**User Manual**

## Table of Contents

<b>1. General information</b>	<b>3</b>
<b>2. Design and function</b>	<b>4</b>
<b>3. Safety</b>	<b>5</b>
<b>4. Transport, packaging and storage</b>	<b>8</b>
<b>5. Usage, operation</b>	<b>9</b>
<b>6. Faults</b>	<b>16</b>
<b>7. Maintenance, cleaning, and calibration</b>	<b>18</b>
<b>8. Dismounting, return and disposal</b>	<b>20</b>
<b>9. Specifications</b>	<b>22</b>

## 1. General information

- The NOSHOK LTI20 Series Radar Level Transmitter described in these operating instructions has been designed and manufactured using state-of-the-art technology. All components are subject to stringent quality and environmental criteria during production. Our quality management systems are certified to ISO 9001
- These operating instructions contain important information on handling the instrument. Working safely requires that all safety notes and work instructions are observed.
- Follow the relevant local accident prevention regulations and general safety regulations for the instrument's range of use.
- The operating instructions are part of the product and must be kept in the immediate vicinity of the instrument and readily accessible to skilled personnel at any time.
- Skilled personnel must have carefully read and understood the operating instructions prior to beginning any work.
- The manufacturer's liability is void in the case of any damage caused by using the product contrary to its intended use, non-compliance with these operating instructions, assignment of insufficiently qualified skilled personnel or unauthorized modifications to the instrument.
- The general terms and conditions contained in the sales documentation shall apply.
- Subject to technical modifications.
- Further information:  
www.noshok.com  
T: 440.243.0888  
F: 440.243.3472  
info@noshok.com

## 2. Design and Function

### 2.1 Scope of delivery

- NOSHOK LTI20 Series Radar Level Transmitter
- Operating instructions
- Ordered accessories

### 2.2 Overview

NOSHOK LTI20 Series Radar Level Transmitter uses free-beam radar technology for level measurement. Electromagnetic waves are emitted and reflected by the surface of the medium. The reflected signals are received and analysed, providing information about the level.

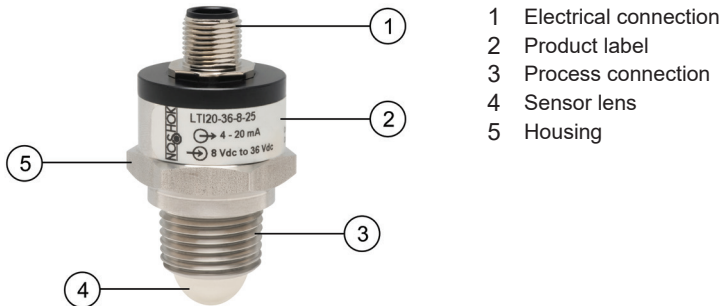

## 3. Safety

### 3.1 Explanation of symbols



#### **WARNING!**

... indicates a potentially dangerous situation that can result in serious injury or death, if not avoided.



#### **CAUTION!**

... indicates a potentially dangerous situation that can result in light injuries or damage to property or the environment, if not avoided.



#### **WARNING!**

... indicates a potentially dangerous situation that can result in burns caused by hot surfaces or liquids, if not avoided.



#### **Information**

... points out useful tips, recommendations and information for efficient and trouble-free operation.

### 3.2 Intended use

The instrument has been designed and built solely for the intended use described here, and may only be used accordingly. The manufacturer shall not be liable for claims of any type based on operation contrary to the intended use.

#### **Intended use**

NOSHOK LTI20 Series Radar Level Transmitter is used to determine the level of oil- and water-based media as well as solids. The range of use is defined by the technical performance limits and materials. The safe operation of the instrument is only ensured if it is used correctly in accordance with the operating instructions and any supplementary instructions.

This instrument is not permitted to be used in hazardous areas.

The instrument has been designed and engineered solely for the intended use described here and may only be used accordingly.

## 3. Safety

The technical specifications contained in these operating instructions must be observed, see chapter ► 9 Specifications. It is assumed that the instrument is handled properly and within its technical specifications. Otherwise, the instrument must be taken out of service immediately and inspected by NOSHOK.

The manufacturer shall not be liable for claims of any type based on operation contrary to the intended use.

### Improper use

Any use beyond or different to the intended use is considered as improper use.

- Refrain from unauthorised modifications to the instrument.
- Do not use in hazardous areas.
- Do not use in safety or emergency shutdown devices.
- Do not use with abrasive and viscous media.
- Do not use with medical devices.
- Do not use in applications with direct contact with food.

### 3.3 Personnel qualification



#### Information

The activities described in these operating instructions may only be carried out by skilled personnel who have the qualifications described below.

#### Skilled personnel

Skilled personnel, authorized by the operator, are understood to be personnel who, based on their technical training, knowledge of measurement and control technology and on their experience and knowledge of country-specific regulations, current standards and directives, are capable of carrying out the work described and independently recognizing potential hazards.

Special operating conditions require further appropriate knowledge, e.g. of aggressive media.

## 3. Safety

### 3.4 Use of accessories and spare parts

It is recommended to use original accessories and original spare parts from NOSHOK. Using accessories and spare parts from third parties can lead to damage to the instrument or accidents, due to quality defects or other reasons.

NOSHOK assumes no liability for damage or accidents caused by a malfunction or unsuitability of accessories and spare parts which do not originate from NOSHOK (e.g. non-compliance with the IP ingress protection of connectors). No warranty claims can be made which arise due to a malfunction or unsuitability of any accessory or spare part from a third party.

## 4. Transport, packaging and storage

### 4.1 Transport

Check the NOSHOK LTI20 Series Radar Level Transmitter for any damage that may have been caused by transport. Obvious damage must be reported immediately.

- Keep the protection cap for subsequent storage or transport.
- Fit the protection cap before dismantling and transporting the instrument.

### 4.2 Packaging and storage

Do not remove packaging until just before use. Keep the packaging as it will provide optimum protection during transport (e.g. change in place of use, sending for repair).

#### **Permissible conditions at the place of storage:**

- Storage temperature: -40 to +158 °F [-40 to +70 °C]
- Humidity: 5 to 95 % relative humidity
- Condensation: non-condensing

#### **Avoid exposure to the following factors:**

- Direct sunlight or proximity to hot objects
- Mechanical vibration, mechanical shock
- Soot, vapor, dust and corrosive gases
- Hazardous/flammable environments

Store the instrument in its original packaging in a location that fulfils the previously listed conditions. Instruments that have already been commissioned must be cleaned before storage, see chapter ► 7.2 "Cleaning".

If the original packaging is not available, pack and store the instrument as described below:

1. Place the instrument in the packaging and evenly pad with shock-absorbent material.
2. If stored for a prolonged period of time (more than 30 days), place a bag containing a desiccant inside the packaging.

## 5. Usage, operation



### **Physical injuries and damage to property and the environment due to hazardous media**

Upon contact with hazardous media (e.g. oxygen, acetylene, flammable or toxic substances) and harmful media (e.g. corrosive, toxic, carcinogenic, radioactive), there is a danger of physical injuries and damage to property and the environment.

Should a failure occur, hazardous media with extreme temperatures (over 131 °F [55 °C]), under high pressure or vacuum may be present at the instrument.

- For these media, in addition to all standard regulations, the appropriate existing codes or regulations must also be followed.

Check the NOSHOK LTI20 Series Radar Level Transmitter for any damage that may have been caused. In the event of any damage, do not use the instrument and contact the manufacturer immediately.

### **5.1 Mounting**

Confirm the torque values of the screws specified in pipefitting work.

In the selection of the mounting material (seals, screws, washers and nuts), take the process conditions into account. The suitability of the seal must be specified with regard to the medium and its vapors. In addition, ensure it has corresponding corrosion resistance.

### **5.2 Mounting Preparation**

1. Ensure that the sealing faces of the vessel or instrument are clean and do not show any mechanical damage.
2. Sensor components, process seals and process interfaces must be in accordance with the installation conditions, and the process pressure, the process temperature and the medium characteristics must correspond to the parameters given on the product label.

## 5. Usage, operation

### 5.3 Tank Requirements - Measuring Range

- To achieve max measuring range, consider beam angle and tank dimensions
- Beam diameter can be calculated with the following equation: Diameter of Beam = 2 x Height x (tan 6°)

**Radar Level Transmitter:  
Beam Pattern and Variable Measurement Area**

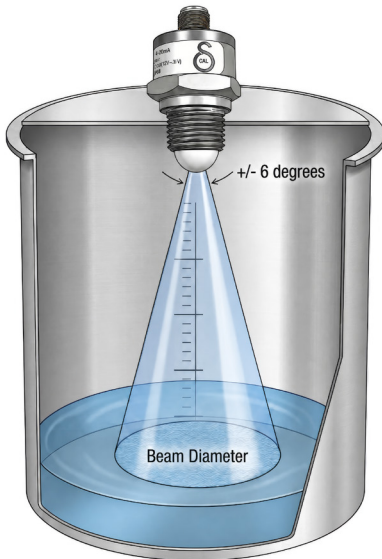

Tank Height (ft)	Diameter of Beam (ft)	Diameter of Beam (in)
25	5.26	63.06
20	4.20	50.45
15	3.15	37.84
10	2.10	25.23
5	1.05	12.61
2	0.42	5.05
1	0.21	2.52

## 5. Usage, operation

### 5.4 Mounting Examples

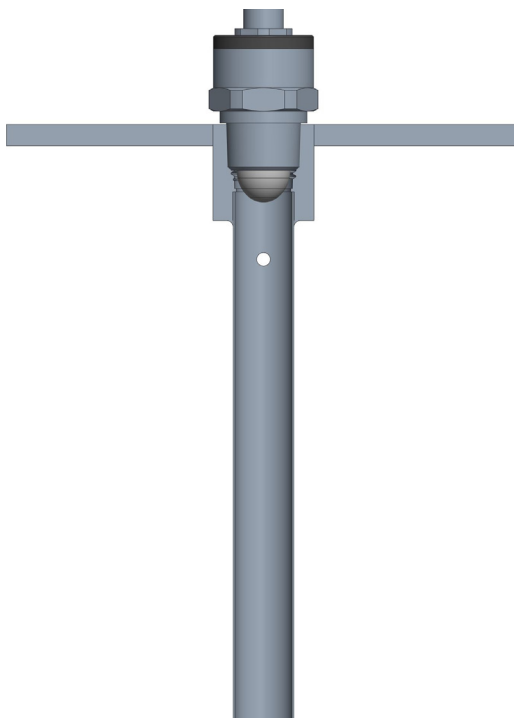

Still Well Mounting

## 5. Usage, operation

### 5.4 Mounting Examples

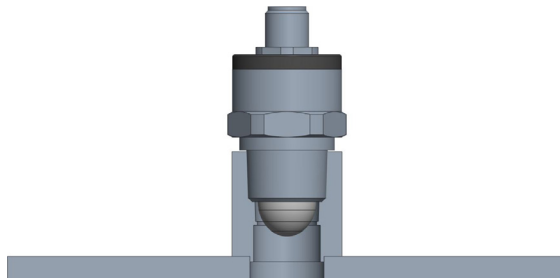

Direct Mounting

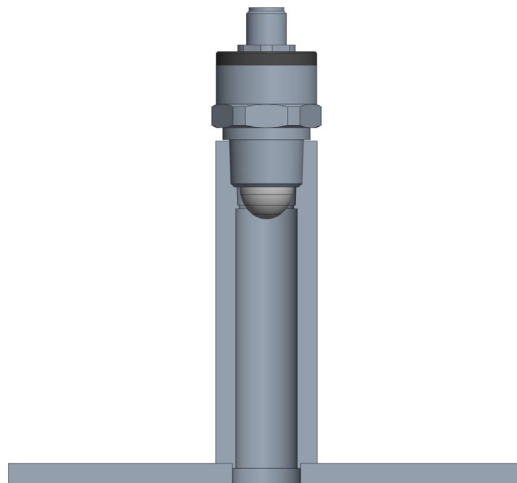

Standoff Mounting

## 5. Usage, operation

### 5.4 Mounting Examples

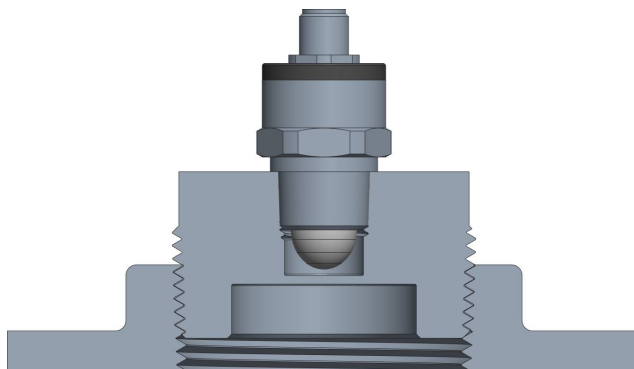

Isolation Adapter Mounting

## 5. Usage, operation

### 5.5 Pin assignment

All connectors with molded cable have the same color assignment as the unshielded cable outlet.

#### Legend

V+	Positive power supply terminal
COMMON	Negative power supply terminal
OUTPUT	Analog signal output
SP1	Switching Output 1
SP2	Switching Output 2

Circular Connector M12 x 1		
4-pin		Level
	1	V+
	2	OUTPUT
	3	COMMON
	4	SP1

Circular Connector M12 x 1		
5-pin		Level + 2 switch points
	1	V+
	2	OUTPUT
	3	COMMON
	4	SP1
	5	SP2

Cable Outlet		
Unshielded		Level
	Brown	V+
	White	COMMON
	Green	OUTPUT
	Yellow	SP1
	Pink	SP2

## 5. Usage, operation

### 5.6 Operating States

4 mA to 20 mA analog output	
4 mA to 20 mA	Target detected within the measuring range
21.5 mA	Target detected outside the measuring range (beyond the upper measuring range limit)
3.8 mA	Target detected outside the measuring range (below the lower measuring range limit)
2.5 mA	No target detected
1mA (<10 seconds)	Calibration, active
2.5 mA (<5 seconds)	Calibration completed

0 V to 5 V analog output	
0 mA to 5 mA	Target detected within the measuring range
5.1 V	Target detected outside the measuring range (beyond the upper measuring range limit)
0 V	Target detected outside the measuring range (below the lower measuring range limit)
2.5 mA	No target detected
1mA (<10 seconds)	Calibration, active
2.5 mA (<5 seconds)	Calibration completed

## 6. Faults



### WARNING!

#### Physical injuries and damage to property and the environment

Upon contact with hazardous media (e.g. oxygen, acetylene, flammable or toxic substances) and harmful media (e.g. corrosive, toxic, carcinogenic, radioactive), there is a danger of physical injuries and damage to property and the environment.

Should a failure occur, hazardous media with extreme temperatures (over 131 °F [55 °C]), under high pressure or vacuum may be present at the instrument.

- For these media, in addition to all standard regulations, the appropriate existing codes or regulations must also be followed.



### INFORMATION

#### Physical injuries and damage to property and the environment caused by hazardous media

If faults cannot be eliminated by means of the listed measures, take the NOSHOK LTI20 Series Radar Level Transmitter out of operation immediately.

- Contact the manufacturer.
- If a return is needed, please follow the instructions given in chapter
  - 8.2 Return.



For contact details see chapter 1 "General information" or the back page of the operating instructions.

In the event of any faults, first check whether the transmitter is mounted correctly, mechanically and electrically.

Fault	Possible cause	Measure
No function	Failure in power supply	Measure voltage, check cable or plug connection.
No valid output signal despite change of level (analogue output signal or switching output)	Electronics defective	Contact the manufacturer.
	Faults/Reflections in the measuring range	Carry out a calibration. If this occurs repeatedly, contact the manufacturer.
	Level fluctuates greatly over a long period of time	Use still well or sheet metal to calm the medium.

## 6. Faults

Fault	Possible cause	Measure
Instrument does not respond or responds too slowly to a change of level	Switching delay, hysteresis	Use an instrument with suitable switching delay, hysteresis.
Output signal longer than 10 seconds > 22 mA or < 2.5 mA (4 mA to 20 mA) 0 V or > 5.1 V (0 V to 5 V)	Electronics defective	Contact the manufacturer.
Output signal longer than 10 seconds > 22 mA or < 2.5 mA (4 mA to 20 mA) 0 V or > 5.1 V (0 V to 5 V)	No valid target detected within the predefined measuring range. Medium is unsuitable. Target at close range not detected.	Carry out a functional test outside the vessel. Contact the manufacturer.
Calibration not possible	Electronics defective, calibration magnet too weak	Use a different magnet, contact the manufacturer.

## 7. Maintenance, cleaning, and calibration

### 7.1 Maintenance

NOSHOK LTI20 Series Radar Level Transmitter operates maintenance- and wear-free when used as intended; however, it must be subjected to visual inspection within the context of regular maintenance and included in the vessel pressure test.

Repairs must only be carried out by the manufacturer.

Only use original parts.

### 7.2 Cleaning



#### CAUTION!

##### Physical Injuries

Residual media can result in a risk to people.

- Carry out the cleaning process in accordance with the manufacturer's instructions.



#### NOTE

##### Damage to property due to improper cleaning

Improper cleaning may lead to damage to the instrument

- Do not use any aggressive cleaning agents.
  - Do not use any hard or pointed objects for cleaning.
  - Do not use any abrasive cloths or sponges.
1. Before cleaning, correctly disconnect the instrument from the pressure supply, switch it off and disconnect it from the mains.
  2. Clean the instrument with a moist cloth. Do not expose the electrical connections to moisture.

### 7.3 Calibration

Mount the instrument. Note the mounting position, see chapter 5.3 Mounting Positions

#### 4 mA to 20 mA signal output

1. Hold the magnet to the marked spot, see the "circle" on the product label.
2. Output signal = 1 mA.
  - The magnet was detected by the instrument
  - Continue to hold the magnet to the marked spot (approx. 10 seconds)
3. Output signal = 2.5 mA
  - Remove the magnet
  - The calibration process is being carried out (approx. 5 seconds).

The calibration process is complete when the output signal jumps to a valid value between 4 mA to 20 mA.

## 7. Maintenance, cleaning, and calibration

### 0 V to 5 V signal output

1. Hold the magnet to the marked spot, see the "circle" on the product label.
2. Output signal = 0 V.
  - The magnet was detected by the instrument
  - Continue to hold the magnet to the marked spot (approx. 10 seconds)
3. Output signal = 2.5 V
  - Remove the magnet
  - The calibration process is being carried out (approx. 5 seconds)
4. The calibration process is complete when the output signal jumps to a valid value between 0 V to 5 V.

## 8. Dismounting, return and disposal



### WARNING!

#### Physical injury

When dismounting, there is a danger from hazardous media and high pressures.

- Check the information in the material safety data sheet for the corresponding medium
- Disconnect the instrument once the system has been depressurized and has cooled down.
- Flush or clean the dismantled instrument (following operation), in order to protect people and the environment from exposure to residual media.



### WARNING!

#### Risk of burns

When dismounting, there is a danger of physical injuries due to dangerously hot instrument surfaces

- Ensure that the instrument has cooled down to ambient temperature



### WARNING!

#### Physical injuries and damage to property and the environment due to hazardous media

Upon contact with hazardous media (e.g. oxygen, acetylene, flammable or toxic substances) and harmful media (e.g. corrosive, toxic, carcinogenic, radioactive), there is a danger of physical injuries and damage to property and the environment.

Should a failure occur, hazardous media with extreme temperatures (over 131 °F [55 °C]), under high pressure or vacuum may be present at the instrument.

- For these media, in addition to all standard regulations, the appropriate existing codes or regulations must also be followed.

### 8.1 Dismounting

Only dismount the instrument once it has been depressurized and disconnected from voltage supply. If necessary, the vessel must have strain relief.

### 8.2 Return



#### Physical injury

Residual media can result in a risk to people.

- Carry out the cleaning process in accordance with the manufacturer's instructions.

#### Strictly follow these rules when shipping the instrument:

- All instruments delivered to NOSHOK must be free from any kind of hazardous substances (acids, bases, solutions, etc.) and must therefore be cleaned before being returned, see chapter ► 7.2 Cleaning.
- When returning the instrument, use the original packaging or a suitable transport packaging.

## 8. Dismounting, return and disposal

### To avoid damage:

1. Wrap the instrument in an anti-static plastic film.
2. Place the instrument in the packaging and pad it evenly with shock-absorbent material.
3. If possible, include a bag with desiccant in the packaging.
4. Label the shipment as transport of a highly sensitive measuring instrument.



Information on returns can be found under the heading "Return Material Authorization (RMA) Policy" on [www.noshok.com](http://www.noshok.com) (RMA application).

### 8.3 Disposal

Incorrect disposal can put the environment at risk. Dispose of instrument components and packaging materials in an environmentally compatible way and in accordance with the country-specific waste disposal regulations.



#### Disposal of electrical equipment

This instrument is manufactured in accordance with the EU Waste Electrical and Electronic Equipment (WEEE) directive. This instrument must not be disposed of with household waste.

- Hand in old instruments for environmentally friendly disposal at a designated collection point for the disposal of electrical and electronic equipment.
- Ensure proper disposal in accordance with national regulations and observe the currently applicable regulations.

## 9. Specifications

### Specifications

#### Overview of versions

Model	Description
LTI20	Standard version up to 212 °F [100 °C]
Optional (-HT)	High-temperature version up to 320 °F [150 °C]

#### Basic Information

Media	Water-based Oil-based Solids
Dielectric constant of the medium	≥ 2
Measurement Frequency	FMCW (60 GHz technology); frequency band 57.4.....61.4 GHz

#### Accuracy Specifications

Non-repeatability	≤ 0.079 in
Accuracy	±0.2 in Per IEC 62828-4

#### Measuring Range

Min. measuring distance to probe tip	4 in
Max. measuring distance to probe tip	300 in [25 ft] → Other measuring distances on request
Beam angle	±6°
Measuring frequency	> 1 Hz
Min. diameter of tank/silo/pipe etc.	1.97 in →Other diameters on request

## 9. Specifications

### Specifications

#### Process connection (with installation from outside)

DIN 3852-2-A	G ½ A →Other process connections on request
ASME B1.20	1/2 NPT

#### Output signal

##### Switching output 1/2 (SP1/SP2)

Switching output	<ul style="list-style-type: none"><li>■ PNP</li><li>■ NPN</li></ul>
Number of switching outputs	Max. 2
Switching function	<ul style="list-style-type: none"><li>■ Normally closed (NC)</li><li>■ Normally open (NO)</li></ul>
Switching delay	Without <ul style="list-style-type: none"><li>■ 1 s<sup>1)</sup></li><li>■ 2 s<sup>1)</sup></li><li>■ 3 s<sup>1)</sup></li><li>■ 5 s<sup>1)</sup></li><li>■ 10 s<sup>1)</sup></li></ul>

##### Analog signal output (S+)

Current (3-wire)	max. 45 mA for versions without 4 mA to 20 mA output signal max. 70 mA for versions with 4 mA to 20 mA output signal
Voltage (3-wire)	max. 600 mA including switching current
Load	600 Ω

##### Auxiliary power

Current output, 4 mA to 20 mA (3-wire)	DC 8 V to 36 V
--	----------------

1) Adjustable only ex-works.

## 9. Specifications

Specifications	
Current output DC 0 V to 5 V (3-wire)	DC 8 V to 36 V
Current supply	Max. 200 mA
Overtoltage resistance	See EMC Directive: EN 61326 emission (group 1, class B) and immunity (industrial environment)
Electrical safety	Protection class III
<b>Dynamic behavior</b>	
Setting time per IEC 62828-1	1 s
Switch-on time	≤ 3 s
<b>Electrical connection</b>	
Connection type	<ul style="list-style-type: none"> <li>■ Circular connector M12 x 1, 4-pin</li> <li>■ Circular connector M12 x 1, 5-pin</li> <li>■ Cable outlet, unshielded</li> </ul>
Wire cross-section	0.25 mm [0.01 in]
Cable diameter	4 ... 10 mm [0.16 ... 0.39 in] (depending on the number of wires)
Cable material	<ul style="list-style-type: none"> <li>■ PVC</li> <li>■ PUR</li> <li>■ Silicone</li> </ul>
Cable length	<ul style="list-style-type: none"> <li>■ 2 m [6.6 ft]</li> <li>■ 5 m [16.4 ft]</li> <li>■ Consult factory for other lengths</li> </ul>
Pin assignment	→See pin assignment
Ingress protection (IP code) per IEC 60529 <sup>2)</sup>	IP67
Short-circuit resistance	Yes

2) The stated ingress protection only applies when plugged in using mating connectors that have the appropriate ingress protection.

## 9. Specifications

### Specifications

Reverse polarity protection	Yes
-----------------------------	-----

#### Materials

##### Materials (wetted)

- |                    |                |
|--------------------|----------------|
| Sensor lens        | ■ PEEK         |
| Process connection | ■ FKM (O-ring) |

##### Materials (in contact with the environment)

- |                               |                       |
|-------------------------------|-----------------------|
| Case                          | Stainless Steel 316   |
| Cable                         | ■ PVC                 |
|                               | ■ PUR                 |
|                               | ■ Silicone            |
| Electrical connection M12 x 1 | ■ Nickel-plated brass |
|                               | ■ PA (Nylon)          |

### Operating conditions

#### Medium temperature limit

- |   |                                       |
|---|---------------------------------------|
| LTI20   | -40 °F to +212 °F [-40 °C to +100 °C] |
| Optional (-HT)  | -40 °F to +302 °F [-40 °C to +150 °C] |
| Ambient temperature limit                               | -40 °F to +212 °F [-40 °C to +100 °C] |
| Storage temperature limit                               | -40 °F to 158 °F [-40 °C to +70 °C]   |
| Pressure limit of medium                                | 0 psi to 362 psi [0 bar to 25 bar]    |
| Vibration resistance per IEC 60068-2-6 (short duration) | 40g, 10 to 2,000 Hz                   |

## 9. Specifications

### Operating conditions

Vibration resistance per IEC 60068-2-6 (long term)	10g, 10 to 2,000 Hz
--	---------------------

Shock resistance per IEC 60068-2-27	100g, 11 ms
-------------------------------------	-------------

### Free fall in line with IEC 60068-2-31

Single instrument	3.28 ft [1 m]
-------------------	---------------

Multiple packaging	1.64 ft [0.5 m]
--------------------	-----------------

Mounting position	Vertical
-------------------	----------

Ingress protection (IP code) per IEC 60529	IP67
--	------

### EMC

ESD per ISO 10605	±8 kV contact discharge, ±15 kV air discharge
-------------------	---

HF field per ISO 11452-2	100 V/m
--------------------------	---------

BCI per ISO 11452-4	200 mA
---------------------	--------

Pulse 1 per ISO 7637-21) <sup>1)</sup>	Level III
--	-----------

Pulse 2a per ISO 7637-21) <sup>1)</sup>	Level III
---	-----------

Pulse 2b per ISO 7637-21) <sup>1)</sup>	Level III
---	-----------

Pulse 3a per ISO 7637-21) <sup>1)</sup>	Level III
---	-----------

Pulse 3b per ISO 7637-21) <sup>1)</sup>	Level III
---	-----------

Fast transient pulses per ISO 7637-3	Level IV
--------------------------------------	----------

Radio disturbances per CISPR 25	30 ... 1,000 MHz
---------------------------------	------------------

1) Does not apply for ratiometric output signal.

## 9. Specifications

### Packaging and instrument labelling

Packaging	<ul style="list-style-type: none"><li>■ Individual packaging</li><li>■ Multiple packaging (up to 50 pieces possible)</li></ul>
Instrument labelling (product label)	<ul style="list-style-type: none"><li>■ NOSHOK product label, adhesive foil</li><li>■ Customized product label on request</li></ul>

### 9.3 Dimensions in mm [in]

#### Temperature Ranges

Standard	-40 °F to 212 °F (-40 °C to 100 °C)
High Temp	-40 °F to 302 °F (-40 °C to 150 °C)

