



LSE20 Series Vibrating Level Switch



Table of Contents

1. General information	3
2. Safety	5
3. Transport, packaging and storage	7
4. Design and function	8
5. Commissioning and operation	9
6. Errors	16
7. Maintenance and cleaning	18
8. Dismounting, return and disposal	19
9. Specifications	21

Declarations of conformity can be found online at www.noshok.com.

1. General information

1. General information

- The instrument described in the operating instructions has been designed and manufactured using state-of-the-art technology. All components are subject to stringent quality and environmental criteria during production. Our management systems are certified in accordance with ISO 9001.
- These operating instructions contain important information on handling the instrument. Working safely requires that all safety instructions and work instructions are followed.
- Follow the relevant local accident prevention regulations and general safety regulations for the instrument's range of use.
- The operating instructions are part of the product and must be kept in the immediate vicinity of the instrument and readily accessible to skilled personnel at any time. Pass the operating instructions on to the next operator or owner of the instrument.
- Skilled personnel must have carefully read and understood the operating instructions prior to beginning any work.
- If available, the provided supplier documentation is also considered to be part of the product in addition to these operating instructions.
- The general terms and conditions contained in the sales documentation shall apply.
- Subject to technical modifications.
- Further information:
www.noshok.com
T: 440.243.0888
F: 440.243.3472
info@noshok.com

1. General information

1.1 Abbreviations, definitions

- Bullet
- Instruction
- 1. ... x. Follow the instruction step by step
- See ... cross-references

1.2 Explanation of symbols



DANGER!

... indicates a directly dangerous situation resulting in serious injury or death, if not avoided.



WARNING!

... indicates a potentially dangerous situation that can result in serious injury or death, if not avoided.



CAUTION!

... indicates a potentially dangerous situation that can result in light injuries or damage to property or the environment, if not avoided.



Information

... points out useful tips, recommendations and information for efficient and trouble-free operation.

2. Safety

2. Safety

2.1 Intended use



DANGER!

Danger to life from intoxication or suffocation

Work on containers involves the danger of intoxication and suffocation.

- Wear the requisite protective equipment

NOSHOK LSE20 vibrating level switches are used exclusively for monitoring the levels of liquid media. The scope of application is defined by the technical performance limits and materials.

- The liquids must not have any large contamination or coarse particles and must not have a tendency to crystallise. Ensure that the wetted parts of the vibrating level switch are sufficiently resistant to the medium being monitored.
- Not suitable for dispersions, abrasive liquids, highly viscous media and colors.
- The operating conditions specified in the operating instructions must be observed.
- Do not operate the instrument in the immediate vicinity of strong electromagnetic fields or in the immediate vicinity of equipment that can be affected by magnetic fields (min. clearance 3 ft [1 m]).
- The vibrating level switches must not be exposed to heavy mechanical loading (impact, bending, vibration).
- The technical specifications contained in these operating instructions must be observed. Improper handling or operation of the instrument outside of its technical specifications requires the instrument to be taken out of service immediately and inspected by NOSHOK.
- The switch points of the LSE20 cannot be changed by the customer.
- The viscosity and density of the medium to be detected should fulfill the following requirements:

Viscosity: 0.1 - 10,000 mPa s

Density: 0.018 - 0.09 lbs/in³

2. Safety

The instrument has been designed and engineered solely for the intended use described here, and may only be used accordingly.

The manufacturer shall not be liable for claims of any type based on operation contrary to the intended use.

2.2 Improper use

- Any use beyond or different to the intended use is considered as improper use.
- Refrain from unauthorized modifications to the instrument.
- Do not use this instrument in safety or emergency shutdown devices.

2.3 Personnel qualification



The activities described in these operating instructions may only be carried out by skilled personnel who have the qualifications described below.

Skilled personnel

Skilled personnel, authorized by the operator, are understood to be personnel who, based on their technical training, knowledge of measurement and control technology and on their experience and knowledge of country-specific regulations, current standards and directives, are capable of carrying out the work described and independently recognising potential hazards.

2.4 Personal protective equipment

The personal protective equipment is designed to protect the skilled personnel from hazards that could impair their safety or health during work. When carrying out the various tasks on and with the instrument, the skilled personnel must wear personal protective equipment.

3. Transport, packaging and storage

3. Transport, packaging and storage

3.1 Transport



CAUTION!

Damage through improper transport

With improper transport, damage to property can occur.

- When unloading packed goods upon delivery as well as during internal transport, proceed carefully and observe the symbols on the packaging.
- With internal transport, observe the instructions in chapter 3.2 “Packaging and storage”.

Check the instrument for any damage that may have been caused.

In the event of any damage, do not commission the instrument and contact the manufacturer immediately.

If the instrument is transported from a cold into a warm environment, the formation of condensation may result in instrument malfunction. Prior to recommissioning, wait for the instrument temperature and the room temperature to equalize.

3.2 Packaging and storage

Do not remove packaging until just before the instrument is used.

Keep the packaging as it will provide optimum protection during transport (e.g. change in place of use, sending for repair).

Permissible conditions at the place of storage:

- Storage temperature: -40 °F to +140 °F [-40 °C to +60 °C]
- Humidity: 5 to 95 % relative humidity (non-condensing)

Avoid exposure to the following factors:

- Direct sunlight or proximity to hot objects
- Mechanical vibration, mechanical shock (putting it down hard)
- Soot, vapor, dust and corrosive gases

Store the instrument in its original packaging in a location that fulfils the previously listed conditions. Instruments that have already been commissioned must be cleaned before storage, see chapter 7.2 “Cleaning”.

If the original packaging is not available, pack and store the instrument as described below:

1. Wrap the instrument in an anti-static plastic film.
2. Place the instrument, along with the shock-absorbent material, in the packaging.
3. If stored for a prolonged period of time (more than 30 days), place a bag containing a desiccant inside the packaging.

4. Design and function

4. Design and function

4.1 Scope of delivery

- Instrument
- Operating instructions

4.2 Description

The LSE20 vibrating level switch is a general-purpose level switch. The core of the vibrating level switch is the vibration drive integrated in the fork body, which drives the fork body up to its resonance frequency. When the fork body is immersed in the medium, the frequency of the fork body decreases and the frequency change is detected by the electronic circuit and is converted to a switching signal. LSE20 vibrating level switch is mainly used for overflow protection in vessels and pipelines, dry run protection and pump operation protection.

5. Commissioning and operation

5. Commissioning and operation



On the wetted parts of the instrument, small residual amounts of the adjustment medium (e.g. compressed air, water, oil) can adhere from production. With increased requirements for technical cleanliness, suitability for the application must be checked by the operator before commissioning.

Check the instrument for any damage that may have been caused. In the event of any damage, do not commission the instrument and contact the manufacturer immediately.

5.1 Mounting preparation

Ensure that the sealing faces of the vessel or vibrating level switch are clean and do not show any mechanical damage. Sensor components (fork body), process seals and process interfaces must be in accordance with the installation conditions, and the process pressure, the process temperature and the medium characteristics must correspond to the parameters given on the product label.

5.2 Switch point

The switch point of the tuning fork is marked by a horizontal notch when installed vertically. The switch point mark should be at the desired height of the switch point during installation. This switch point is set at the factory using “water” as a test medium.

Switch point accuracy:	± 0.08 in [± 2 mm]
Switch hysteresis:	≤ 0.12 in [≤ 3 mm]
Repeat accuracy:	0.004 in [0.1 mm]
Response time:	<ul style="list-style-type: none">■ Covered by media 0.5 seconds■ Uncovered by media 1.0 seconds

The tuning fork body is available in two different lengths: 1.50 in [38 mm] or 1.65 in [42 mm].

5. Commissioning and operation

Tuning fork body, 1.50 in [38 mm]

Mounting situation	Switch point
Tuning fork mounted vertically downwards	0.51 in [13 mm], measured from the lower edge of the vibrating body tip
Tuning fork mounted vertically upwards	1.3 in [32 mm], measured from the upper edge of the fork extension
Tuning fork mounted horizontally	0.16 in [4 mm] above the centre of the tuning fork

Tuning fork length, 1.50 in [38 mm]

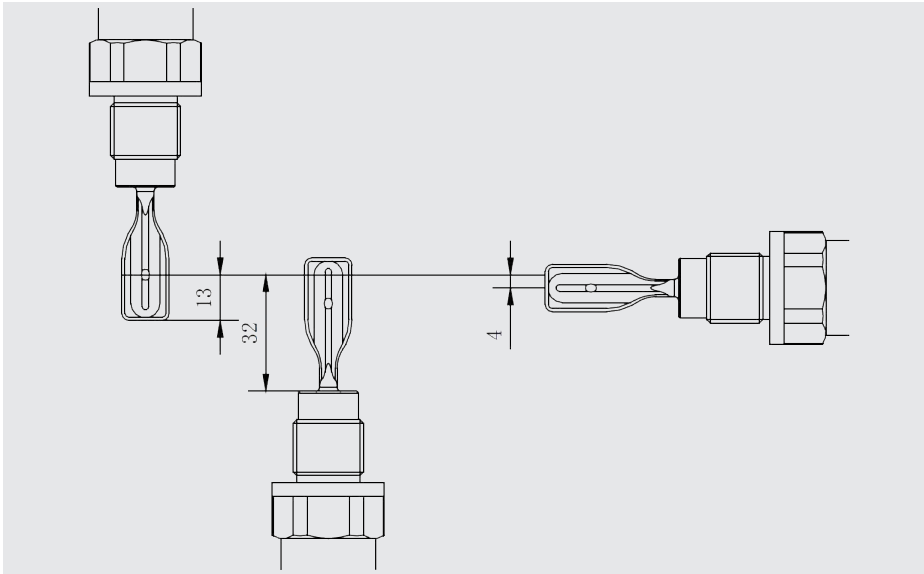

5. Commissioning and operation

Tuning fork body, 1.65 in [42 mm], standard length (Ex. 3/4 NPT)

Mounting situation	Switch point
Tuning fork mounted vertically downwards	0.51 in [13 mm], measured from the lower edge of the vibrating body tip
Tuning fork mounted vertically upwards	1.3 in [32 mm], measured from the upper edge of the fork extension
Tuning fork mounted horizontally	0.16 in [4 mm] above the centre of the tuning fork

Tuning fork length, 1.65 in [42 mm]

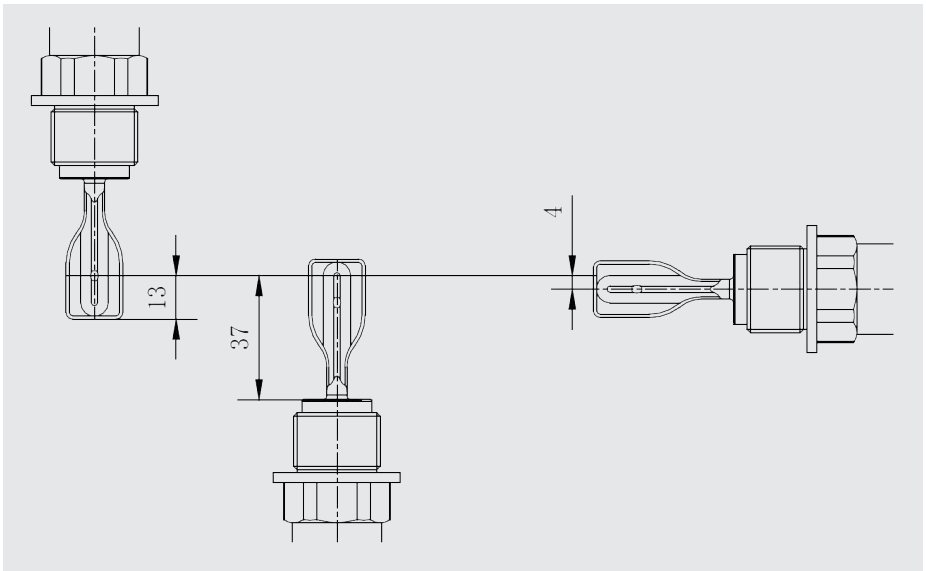

5.3 Mounting

- Observe the torque values in pipefitting work.
- In the selection of the mounting material (seals, screws, washers and nuts), take the process conditions into account. The suitability of the seal must be specified with regard to the medium and its damping. In addition, ensure it has corresponding corrosion resistance.

Installation in vessels

In the case of horizontal installation, the alignment mark of the vibrating level switch must point upwards. When installing, ensure that there is sufficient clearance between the vessel wall and the fork body.

5. Commissioning and operation

If the kinematic viscosity range is between 0 ... 2,000 cSt, the distance between the fork body and the vessel wall should be at least 0.98 in [25 mm]. When using a process connection flange, a minimum nominal width of \geq DN 50 is recommended.

In-pipe installation

If the vibrating level switch is installed within a pipeline system, make sure that the alignment mark points in the same direction as the flow direction of the process medium. With horizontal installation, make sure that no build-up of the medium at the tuning fork bodies is possible. The tuning fork bodies must always be aligned vertically.

5.3.1 Cleaning in place (CIP) cleaning process

- The vibrating level switch does not need to be dismantled and removed for cleaning (= cleaning in place).
- Only use cleaning agents which are suitable for the seals used.
- Cleaning agents must not be abrasive nor corrosively attack the materials of the wetted parts.
- Avoid thermal shocks or fast temperature changes. The temperature difference between the cleaning agent and rinsing with clear water should be as low as possible.
- Negative example: Cleaning at 80 °C [176 °F] and rinsing at 4 °C [39 °F] with cold water.
- For tank-mounted sensors the tank cleaning devices shall be positioned in such a way that the sensor can be assessed and is perfectly cleaned.

5.4 Electrical connection



CAUTION!

Damage to property through failure of the current pulse signal

The current pulse signal may fail due to the use of a longer cable or a cable laid in conjunction with power cables.

- Use shielded cable and the provided ground terminals.

The electrical connection may only be established once the vibrating level switch has been installed in its final installation position.

Models LSE20 with DIN 175301 connector

1. Loosen the screw on the top of the connector and remove both male and female connector, see chapter 8.1 "Dismounting".
2. Unscrew the cable connection of the connector and remove the terminal inside the connector.
3. Remove the outer sheath of the connection cable (approx. 1.97 in [5 cm]) and the wire insulation (approx. 0.39 in [1 cm]).
4. Feed the cable through the cable connector and plug it into the connector case.
5. Connect the end of the stranded wire to the terminal in accordance with the wiring scheme.
6. Insert the terminal into the connector case.
7. Insert the male and female connector and tighten the screw on top of the connector.

5. Commissioning and operation

Models LSE20 with M12 coupler connector

1. Align the positioning mark on the M12 female connector with the positioning mark on the mating connector on the vibrating level switch.
2. Connect the M12 connector to the corresponding mating connector.
3. Tighten the lock nut on the outside of the M12 connector.
4. Ensure that the connectors are firmly connected to each other.

Model LSE20 with DIN 175301 connector

PNP output

The supply voltage is 10 Vdc to 30 Vdc

Max.

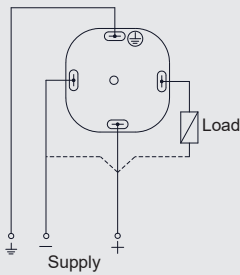

Min.

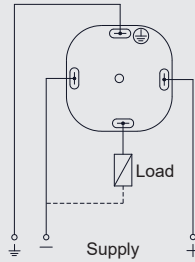

Model LSE20 with M12 coupler connector

PNP output

The supply voltage is 10 Vdc to 30 Vdc.

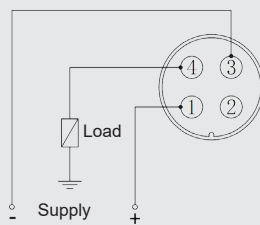
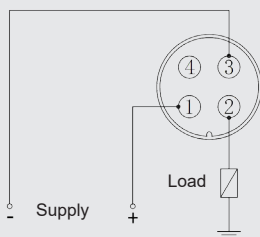

5. Commissioning and operation







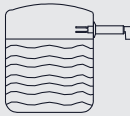

5.5 Status LED/ Switching Function

The following tuning fork types have a status LED to indicate the switching and error states.

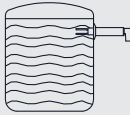
- LSE20 with DIN 175301 coupler connector

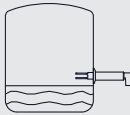

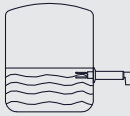

Version	Status LED
LSE20 with DIN 175301 coupler connector	Directly below the coupler connector

Model LSE20, PNP transistor signal output

	Level	Switching status	Status LED
Max. level			Steady red light
			Steady green light
Min. level			Steady green light
			Steady red light
Error state	-	-	Flashing red light

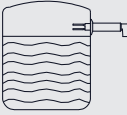
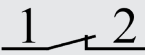
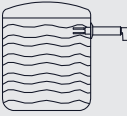
5. Commissioning and operation

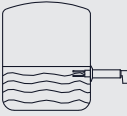
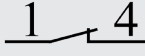
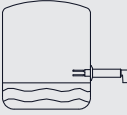
Model LSE20 with M12 coupler connector, PNP transistor signal output

	Level	Switching status
Max. level		
		
Min. level		
		
Error state	-	-

6. Errors

6. Errors

Personnel: Skilled personnel



If faults cannot be eliminated by means of the listed measures, the instrument must be taken out of operation immediately.

- Contact the manufacturer.
- If a return is needed, please follow the instructions given in chapter 8.2 "Return".



For contact details, see chapter 1 "General information" or the back page of the operating instructions.

Errors	Causes	Measures
The power supply is connected, but the tuning fork is not vibrating. The status LED is off.	Error in the electrical wiring. The power supply is connected incorrectly.	Check the electrical wiring with the instrument-specific connection diagram.
	Electronics are defective.	Contact the manufacturer.
The power supply is connected and the tuning fork is vibrating. The status LED is off.	Status LED is defective.	Contact the manufacturer.
	Electronics are defective.	Contact the manufacturer.
The power supply is connected and the status LED is blinking.	Status LED is defective.	Contact the manufacturer.
	Electronics are defective.	Contact the manufacturer.
	The mechanics of the tuning fork are damaged.	Check the tuning fork for external damage and contact the manufacturer.
The power supply is connected and the tuning fork is vibrating. The LEDs light up in reverse order.	Error in the electrical wiring. The power supply is connected incorrectly.	Check the electrical wiring with the instrument-specific connection diagram.
	Electronics are defective.	Contact the manufacturer.

6. Errors

Errors	Causes	Measures
The tuning fork is not covered with medium, but there is a switching process (incl. change in voltage and status change of the LED).	Supply voltage is too low	Check the supply voltage
	Electronics are defective.	Contact the manufacturer.
	Build-up on the tuning fork	Check the tuning fork for contamination or build-up in the area of the wetted parts and remove.
	For pipeline applications: installation position not the same as the flow direction	Adjust the installation orientation of the vibrating level switch. (Align the tuning fork in the flow direction of the medium)
The actual switch point deviates from the previously set switch point.	Density of the process medium deviates from the test medium (water)	No adjustment of the vibrating level switch possible on site. Contact the manufacturer.
	The mechanics of the tuning fork are damaged.	Contact the manufacturer.
The tuning fork is covered with media but there is no switching operation.	The mechanics of the tuning fork are damaged.	Contact the manufacturer.
The tuning fork is covered with media but the switching status is constantly changing.	Rapid level changes of the process medium	No adjustment of the vibrating level switch possible on site. Contact the manufacturer.
	Electronics are defective.	Contact the manufacturer.
	The mechanics of the tuning fork are damaged.	Contact the manufacturer.

7. Maintenance and cleaning

7. Maintenance and cleaning

Personnel: Skilled personnel



For contact details, see chapter 1 “General information” or the back page of the operating instructions.

7.1 Maintenance

The LSE20 vibrating level switches operate maintenance-free and wear-free when used as intended. They must be subjected to visual inspection within the context of regular maintenance, however, and included in the vessel pressure test.



DANGER!

Danger to life from intoxication or suffocation

Work on containers involves the danger of intoxication and suffocation.

- Wear the requisite protective equipment

Repairs must only be carried out by the manufacturer.

7.2 Cleaning



CAUTION!

Physical injuries and damage to property and the environment

Residual media can result in a risk to persons, the environment and equipment.

- Wear the requisite protective equipment.
- Carry out the cleaning process in accordance with the manufacturer’s instructions.



CAUTION!

Damage to property due to improper cleaning

Improper cleaning may lead to damage to the instrument.

- Do not use any aggressive cleaning agents.
- Do not use any hard or pointed objects for cleaning.
- Do not use any abrasive cloths or sponges.

1. Before cleaning, correctly disconnect the instrument from the process, switch it off and disconnect it from the mains.
2. Clean the instrument with a moist cloth.
Electrical connections must not come into contact with moisture.
3. Wash or clean the dismantled instrument, in order to protect persons and the environment from exposure to residual media.

8. Dismounting, return and disposal

8. Dismounting, return and disposal

Personnel: Skilled personnel



WARNING!

Physical injury

When dismantling, there is a danger from hazardous media.

- Wear the requisite protective equipment, see chapter 2.4 “Personal protective equipment”.
- Wash or clean the dismantled instrument (following operation), in order to protect persons and the environment from exposure to residual media.



WARNING!

Risk of burns

During dismantling there is a risk of dangerously hot media escaping.

- Wear the requisite protective equipment, see chapter 2.4 “Personal protective equipment”.
- Let the instrument cool down to room temperature before dismantling it.



WARNING!

Physical injuries and damage to property and the environment caused by hazardous media

Upon contact with hazardous media (e.g. oxygen, acetylene, flammable or toxic substances) or harmful media (e.g. corrosive, toxic, carcinogenic, radioactive), there is a danger of physical injuries and damage to property and the environment.

Hazardous media may adhere to or escape from the instrument should a failure occur.

- For these media, in addition to all standard regulations, the appropriate existing codes or regulations must also be followed.
- Wear the requisite protective equipment, see chapter 2.4 “Personal protective equipment”.

8.1 Dismounting

Only disconnect the instrument once the system has been depressurized and the power disconnected.

If necessary, the vessel must have strain relief.

8. Dismounting, return and disposal

8.2 Return

Strictly observe the following when shipping the instrument:

- All instruments delivered to NOSHOK must be free from any kind of hazardous substances (acids, bases, solutions, etc.) and must therefore be cleaned before being returned, see chapter 7.2 “Cleaning”.
- When returning the instrument, use the original packaging or a suitable transport packaging.



With hazardous substances, include the material safety data sheet for the corresponding medium.

To avoid damage:

1. Wrap the instrument in an anti-static plastic film.
2. Place the instrument, along with the shock-absorbent material, in the packaging.
3. If possible, place a bag, containing a desiccant, inside the packaging.
4. Label the shipment as carriage of a highly sensitive measuring instrument.



Information on returns can be found under the heading “Support” on the NOSHOK website (product return form).

8.3 Disposal

Incorrect disposal can put the environment at risk.

Dispose of instrument components and packaging materials in an environmentally compatible way and in accordance with the country-specific waste disposal regulations.

9. Specifications

9. Specifications

9.1 Model LSE20

Vibrating level switch LSE20

Technical data	
Electrical connection	<ul style="list-style-type: none"> ■ DIN EN 175301-803 ■ M12 x 1 (4-pin)
Process connection	<ul style="list-style-type: none"> ■ 1/2" NPT ■ 3/4" NPT ■ 1" Tri-Clamp ■ 1-1/2" Tri-Clamp ■ 2" Tri-Clamp
Insertion length for industrial*	3"
Insertion length for sanitary*	2-3/8"
Switching output	PNP/3-wire (Transistor PNP)
Accuracy parameters	
Switchpoint accuracy	+/-0.08 inches (+/- 2 mm)
Switch hysteresis	≤ 0.12 in (3 mm)
Repeatability	0.004 inches (0.1 mm)
Response time	Covered by media - 0.5 seconds Uncovered by media - 1.0 seconds
Density of media	0.018...0.09 lbs/in ³ (0.5 ... 2.5 g/cm ³)
Viscosity	0.1...10,000 mPa s (0.1 ... 10,000 cP)
Temperature ranges	
Media	Sanitary -40 °F to 302 °F (-40 °C to 150 °C) Standard -40 °F to 212 °F (-40 °C to 100 °C) High Temp -40 °F to 302 °F (-40 °C to 150 °C)
Ambient	-40 °F to 140 °F (-40 °C to 60 °C)
Storage	-40 °F to 140 °F (-40 °C to 60 °C)
LED status	Green: Open Red: Closed Flashing Red: Error
Power requirement	10 Vdc to 30 Vdc
Power consumption	< 1 W
Operating pressure	-15 psi to 930 psi (-1 bar to 64 bar)
Housing material	316L Stainless Steel
Wetted parts	316 Stainless Steel, Optional: Hastelloy C-276

9. Specifications

Technical data	
Sanitary wetted parts	Ra < 30µin (0.76 µm) ASME BPE SF3
Environmental rating	M12x1 (4-pin) - IP66/68, DIN Form A - IP65 per IEC 60529
Electromagnetic rating	RFI, EMI and ESD protection
Electrical protection	Protected against reverse polarity, over-voltage and short circuit
Weight	Approximately 7 oz.

*Other lengths available, consult factory



ISO 9001:2015
REGISTERED