

Dimensions

Flange-Flange

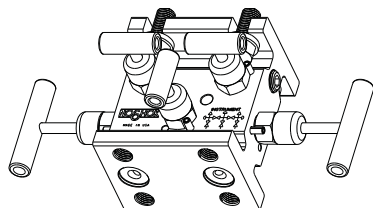

Top View

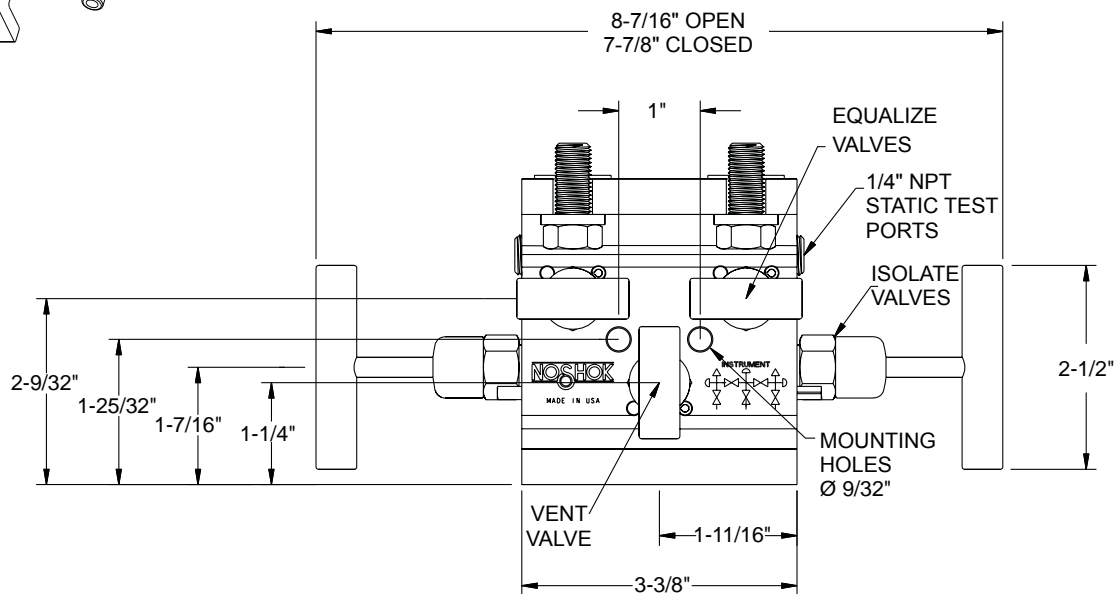

Front View

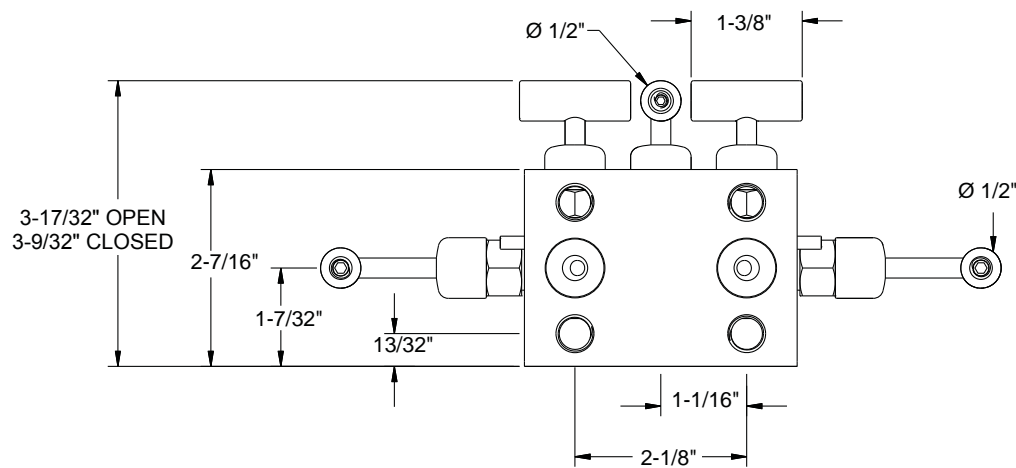

Side View

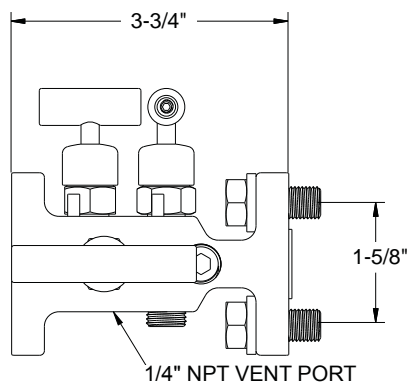

Flange-Female

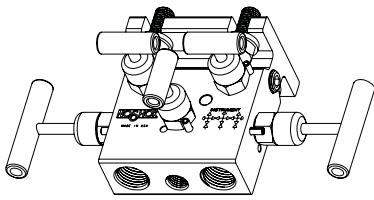

Top View

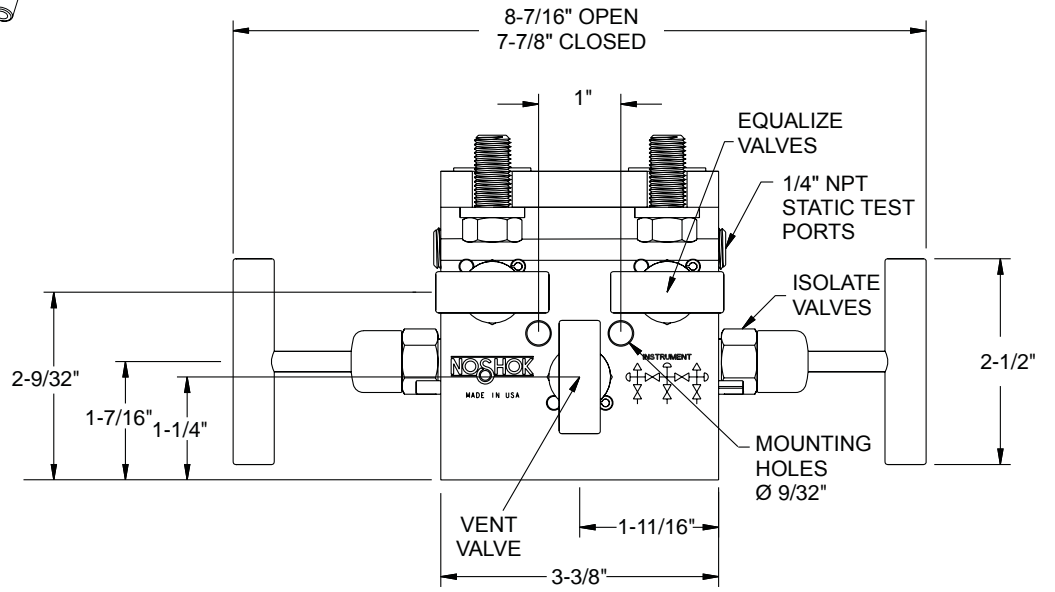

Front View

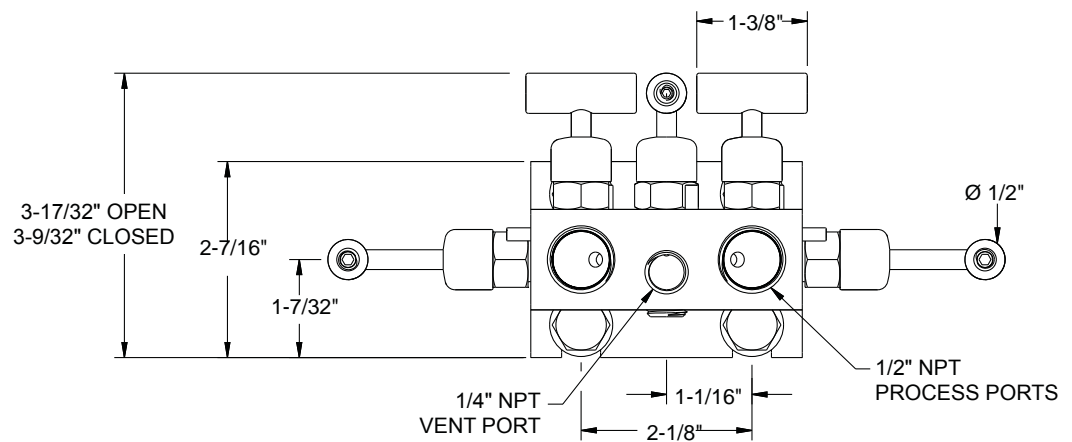

Side View

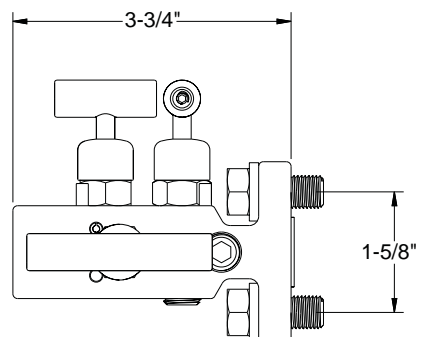

Dimensions

Female-Female

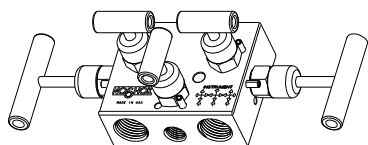

Top View

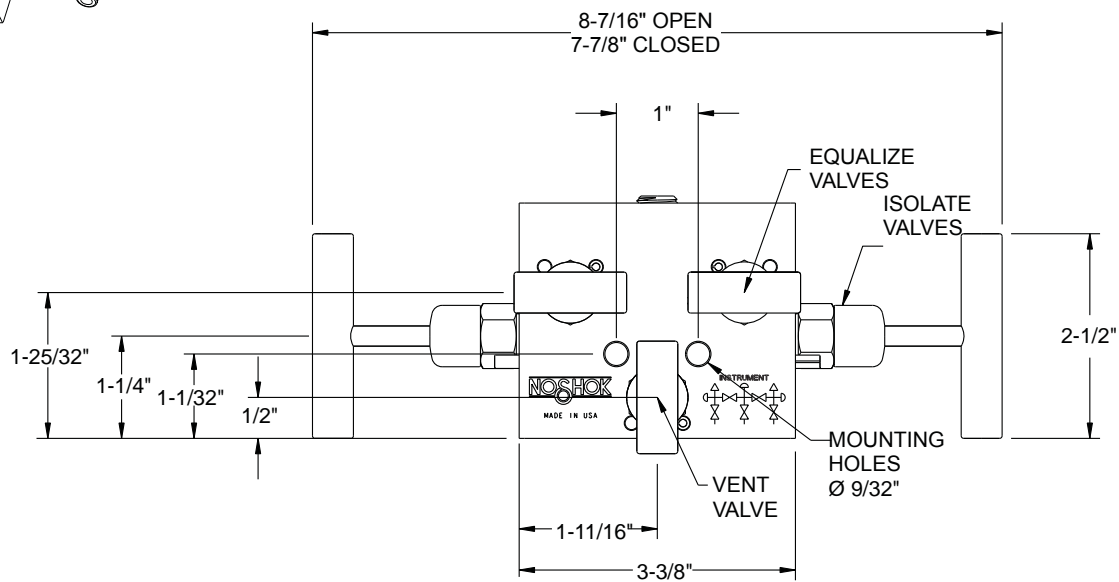

Front View

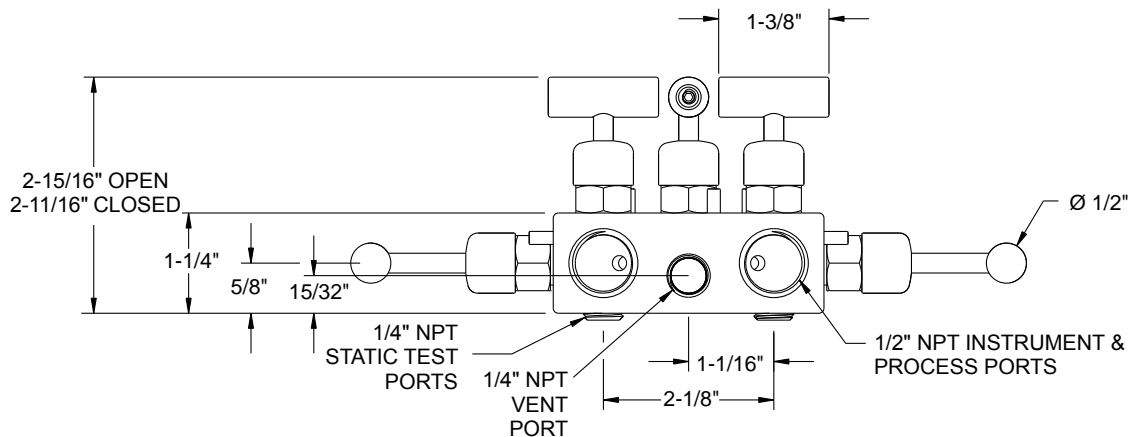

Side View

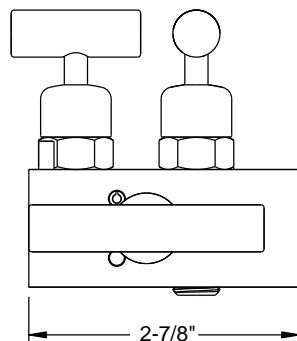

For panel mount and packing dimensions, see pgs. 64-65.

Hard Seat

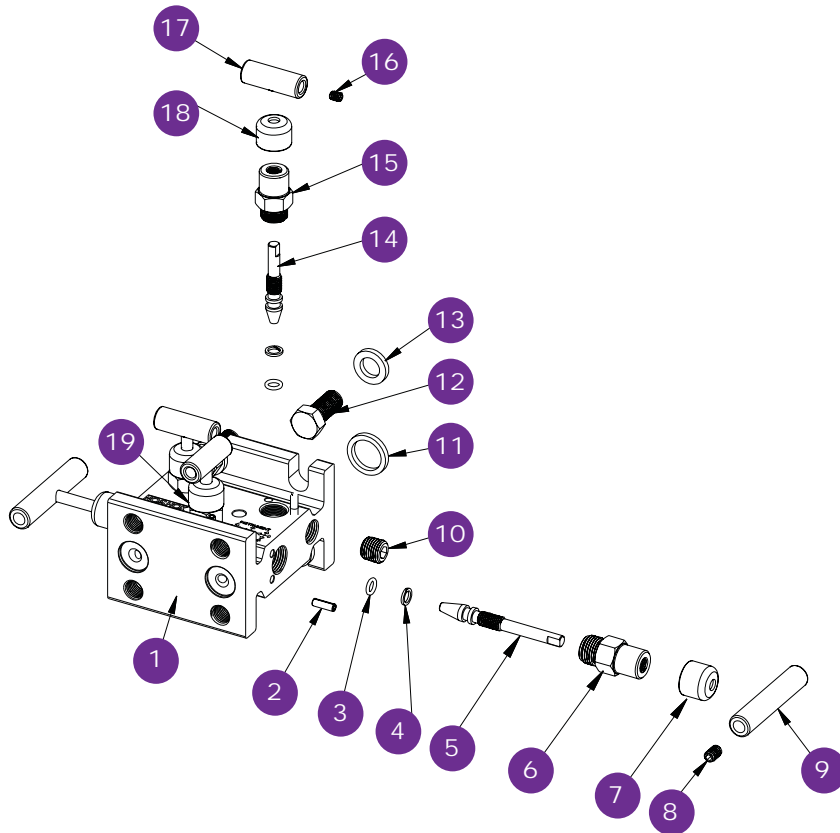

- 1 Valve body
- 2 Slotted spring pin
- 3 FKM o-ring
- 4 PTFE back-up ring
- 5 Valve stem
- 6 Valve bonnet
- 7 Blue dust cap
- 8 Set screw
- 9 Valve "T" handle
- 10 Plug
- 11 Gasket ring
- 12 Head bolt
- 13 Washer
- 14 Mini valve stem
- 15 Mini valve bonnet
- 16 Set screw
- 17 Mini valve "T" handle
- 18 Green dust cap
- 19 Red dust cap

Soft Seat

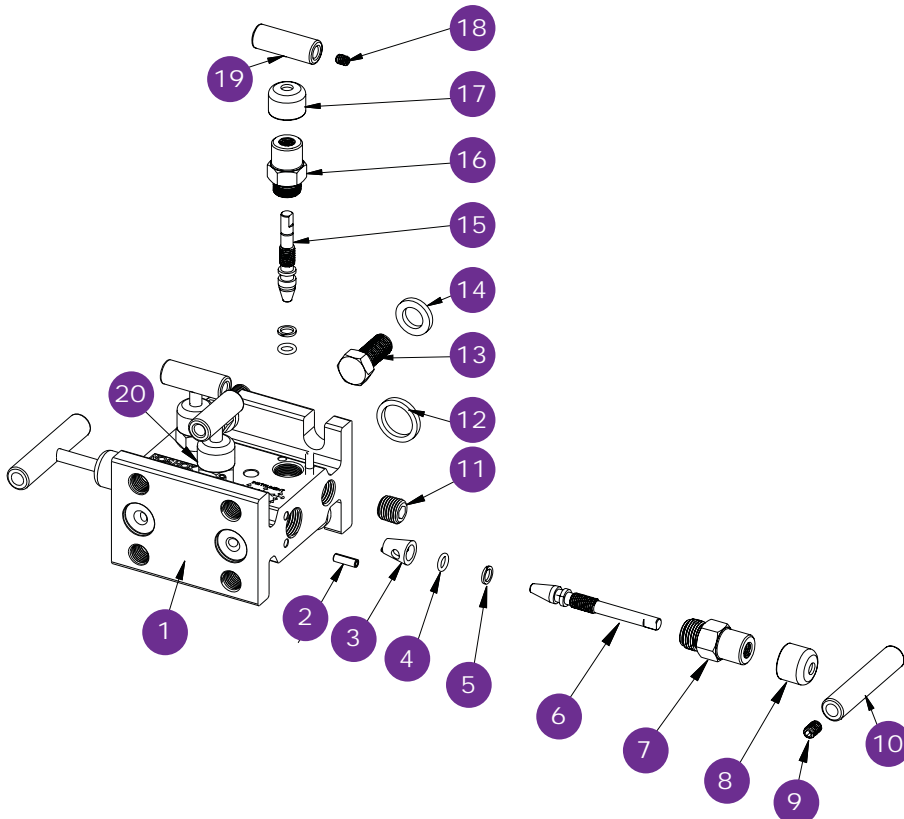

- 1 Valve body
- 2 Slotted spring pin
- 3 Delrin® seat
- 4 FKM o-ring
- 5 PTFE back-up ring
- 6 Valve stem
- 7 Valve bonnet
- 8 Blue dust cap
- 9 Set screw
- 10 Valve "T" handle
- 11 Plug
- 12 Gasket ring
- 13 Head bolt
- 14 Washer
- 15 Soft tip stem
- 16 Mini valve bonnet
- 17 Green dust cap
- 18 Set screw
- 19 Mini valve "T" handle
- 20 Red dust cap

Flare Pattern™ Flange-Female

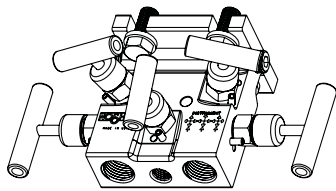

Top View

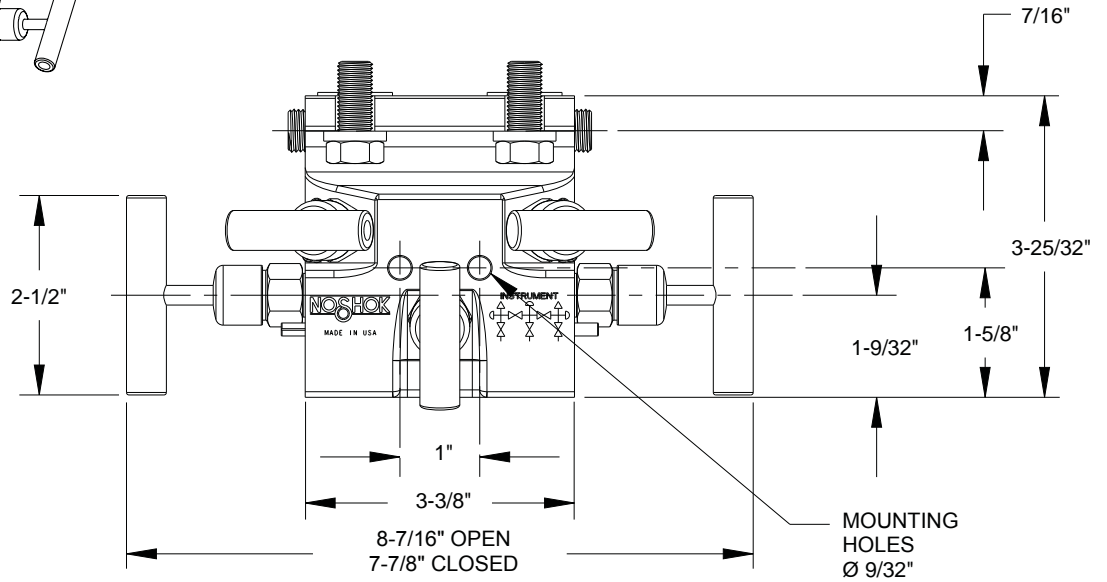

Front View

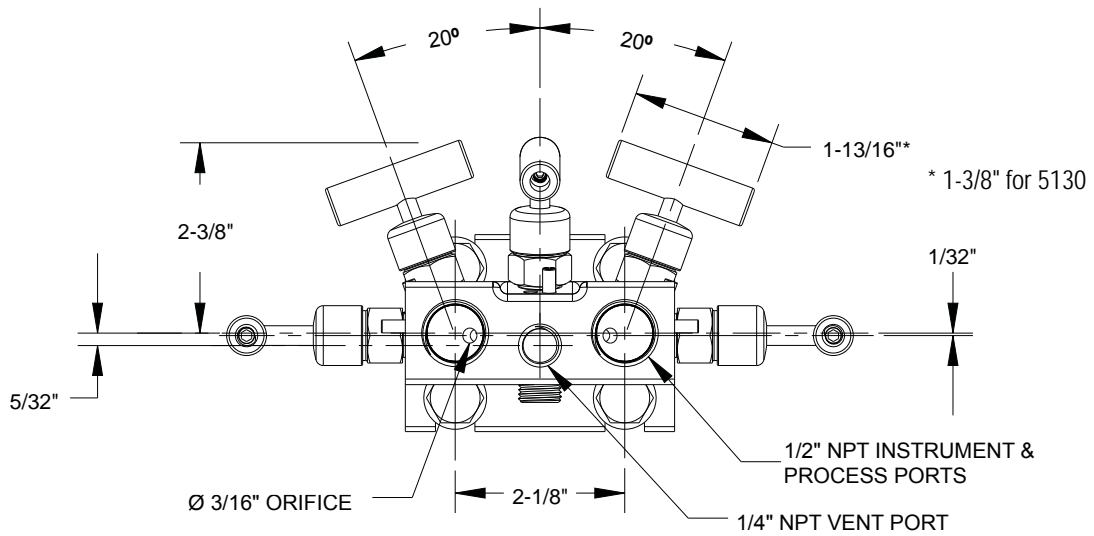

Side View

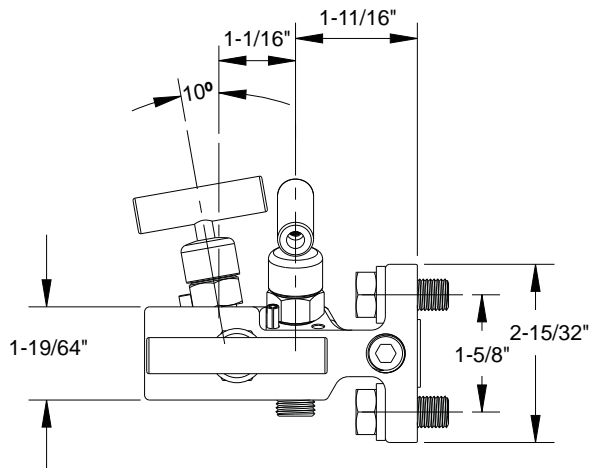

Dimensions

Flare Pattern™ Female-Female

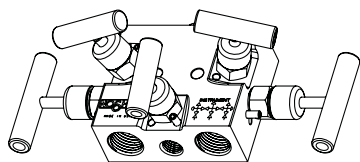

Top View

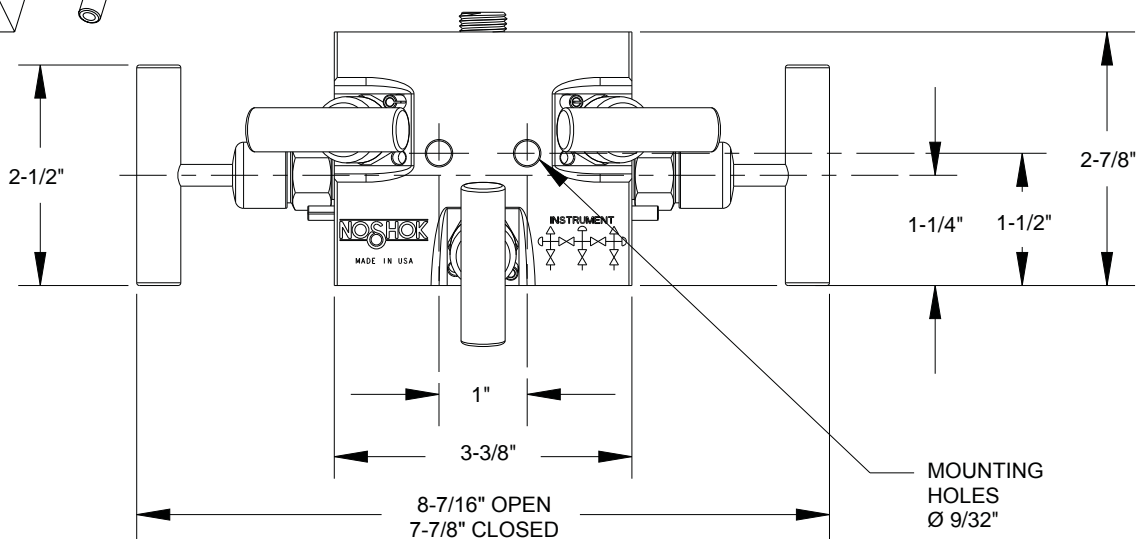

Front View

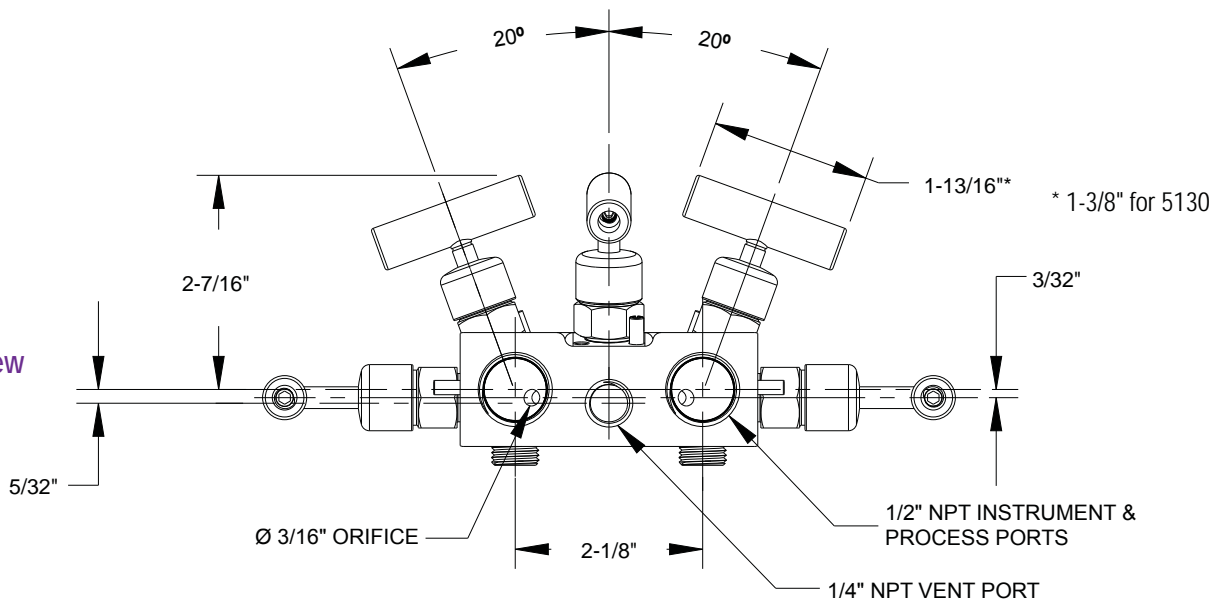

Side View

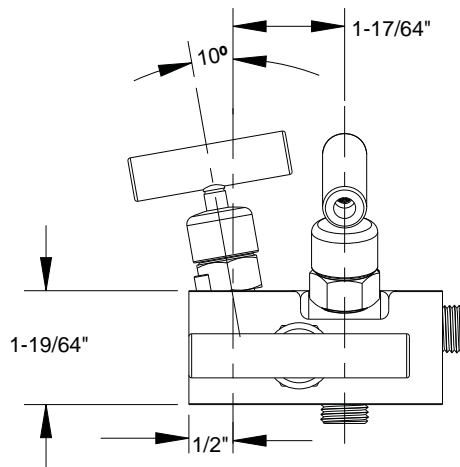

For panel mount and packing dimensions, see pgs. 64-65.

Hard Seat

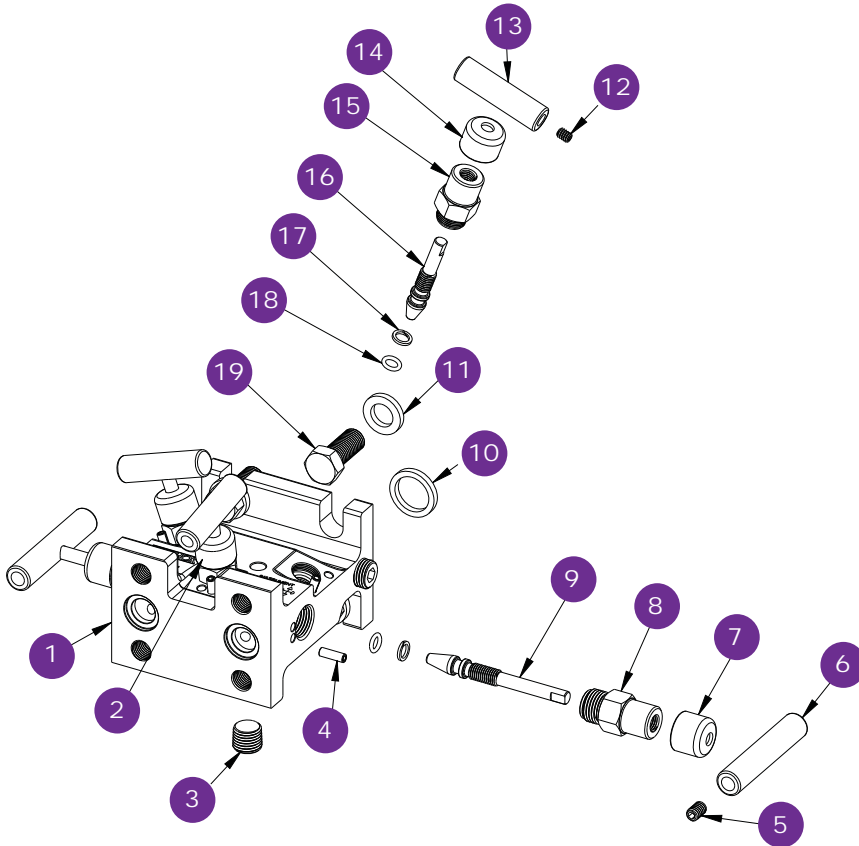

- 1 Flare Pattern™ valve body
- 2 Red dust cap
- 3 Plug
- 4 Slotted spring pin
- 5 Set screw
- 6 Valve "T" handle
- 7 Blue dust cap
- 8 Valve bonnet
- 9 Valve stem
- 10 Gasket ring
- 11 Washer
- 12 Set screw
- 13 Mini valve "T" handle
- 14 Green dust cap
- 15 PTFE back-up ring
- 16 Valve stem
- 17 PTFE back-up ring
- 18 FKM o-ring
- 19 Head bolt

Soft Seat

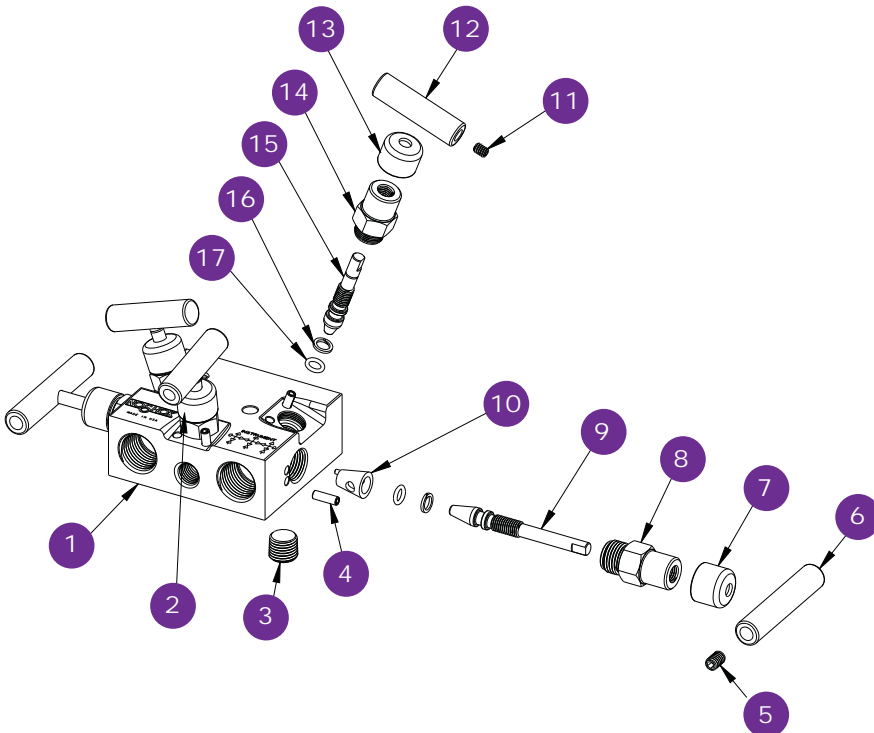

- 1 Flare Pattern™ valve body
- 2 Red dust cap
- 3 Plug
- 4 Slotted spring pin
- 5 Set screw
- 6 Valve "T" handle
- 7 Blue dust cap
- 8 Valve bonnet
- 9 Valve stem
- 10 Soft seat
- 11 Set screw
- 12 Mini valve "T" handle
- 13 Green dust cap
- 14 Valve bonnet
- 15 Soft tip stem
- 16 PTFE back-up ring
- 17 FKM o-ring